

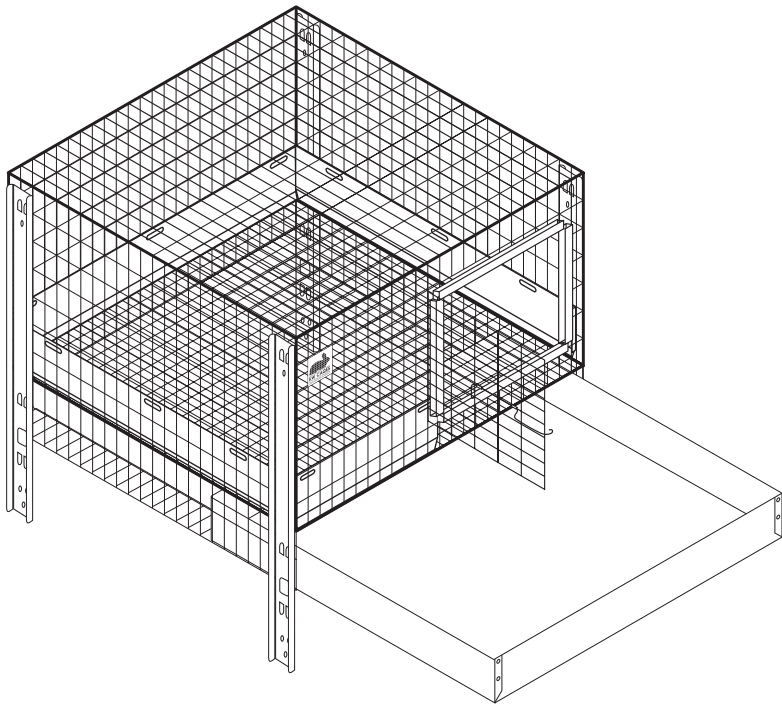

Series 3000

ASSEMBLY INSTRUCTIONS

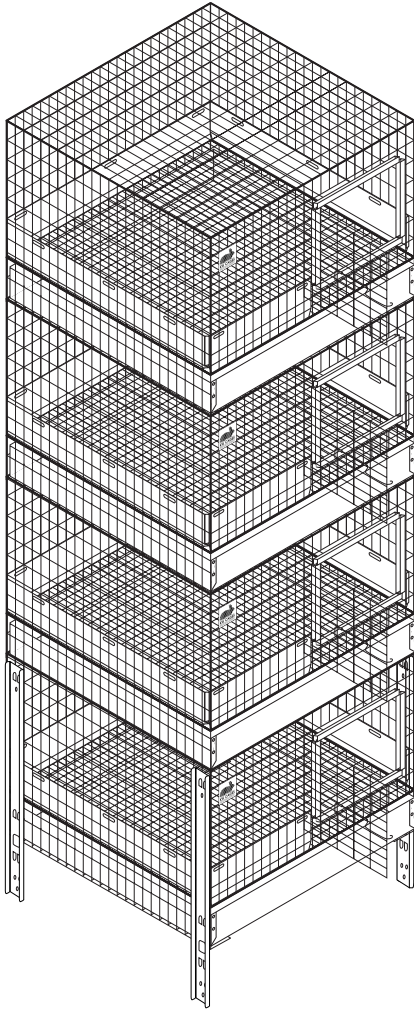

Size

SKU	(L x W x H)	Comps.
3680	36" X 24" X 14"	2
3638	30" X 24" X 14"	1
3627	24" X 24" X 14"	1
3656	18" X 24" X 14"	1

MADE IN



U. S. A.

Drawing is representative of most models. Some variations between models may occur. Leg base kit sold separately.

WARNING



Wire panels and sheetmetal parts may have sharp edges, especially when handled as loose components. Use caution when handling or performing cage assembly and maintenance. Always wear gloves and safety eye-protection to help reduce the chance of personal injury.



Series 3000

ASSEMBLY INSTRUCTIONS

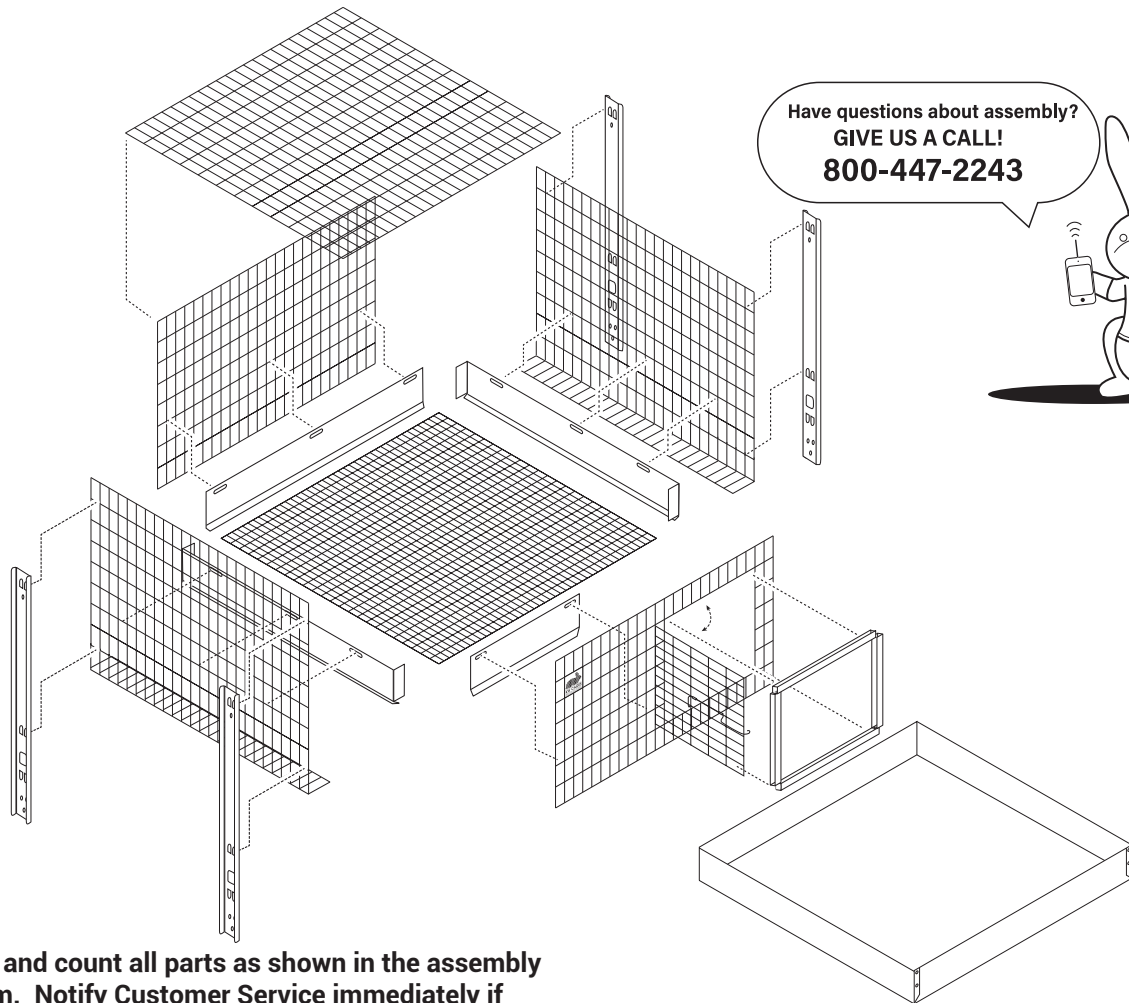

Have questions about assembly?
GIVE US A CALL!
800-447-2243



Layout and count all parts as shown in the assembly diagram. Notify Customer Service immediately if any parts are missing or damage has occurred during shipment.

Part List

	Qty	Description		Qty	Description		
	A	1	Front, Back, Floor sub assembly		G	4	Door Guard
	B	2	Cage Foot		H	1	Sliding Tray
	C	2	Deflector - Side		I	1	Solid Partition (Model 3680 Only)
	D	1	Deflector - Front *		J	1	Pack of Cage Clips
	E	1	Deflector - Back *		K	Opt.	Leg Base Kit (sold separately)
	F	1	Top	* Model 3680 Has 2 Front / 2 Back Deflectors + a pack of cage rings for partition installation.			



✓ Step-By-Step

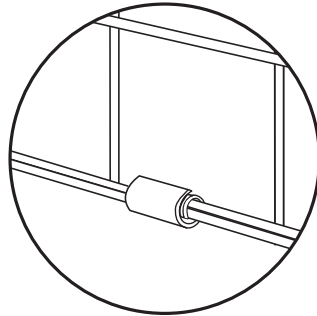
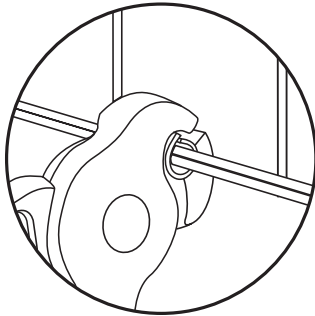
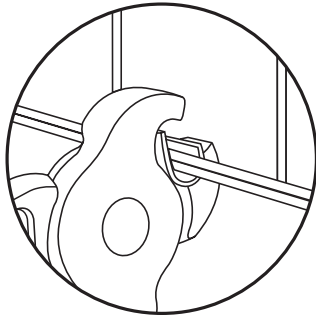
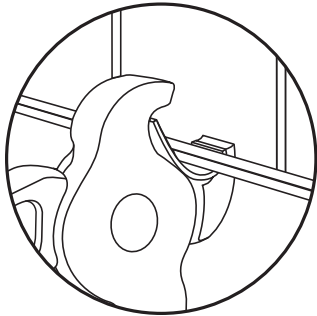

Cage clip pliers are recommended for assembly.

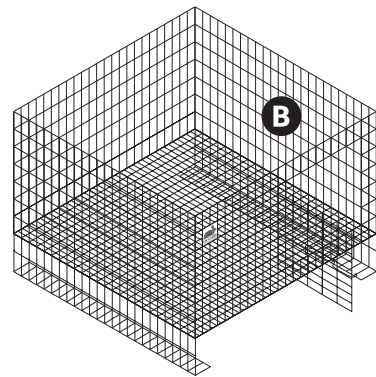
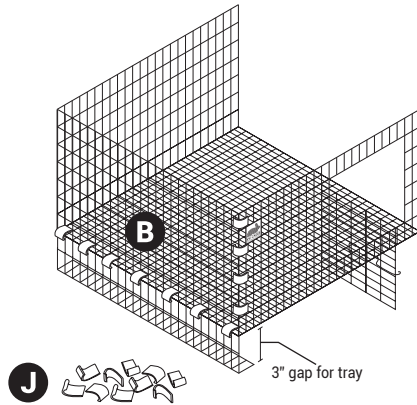
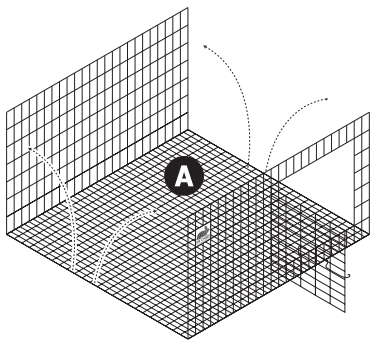

1 Start with assembly (A). Swing front panel and back panel upward to create "U" shape as shown.

2 Attach left cagefoot panel (B) to front assembly and flooring using cage clips (J) every four inches as shown.

3 Attach right panel (B) in a similar way. Note: For model 3680 (2 compartments) install partition in center of cage using cage rings.

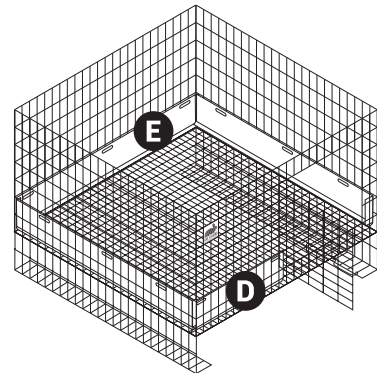
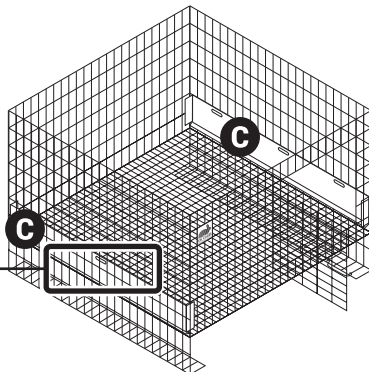
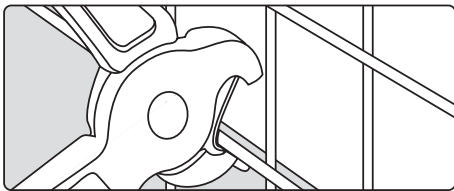

4 Attach left & right side deflectors (C) using one cage clip at each slot. Note: left and right side deflectors have tabs at each end.

5 Attach front (D) and back (E) deflectors using cage clips at each slot.



✓ Step-By-Step

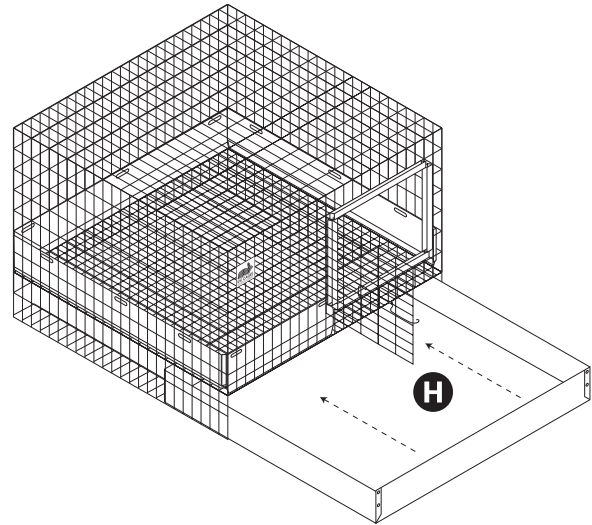
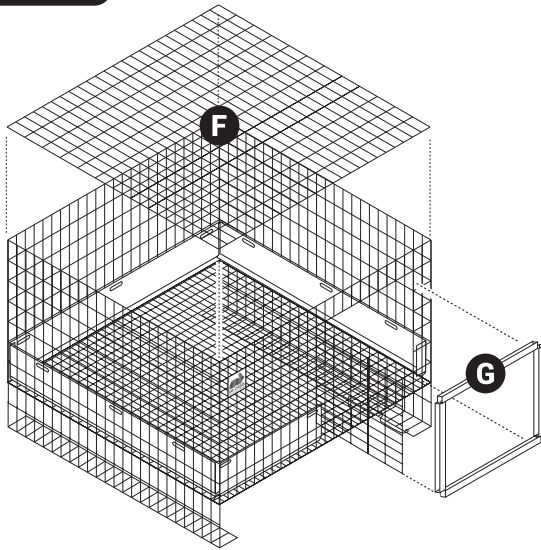

6 Attach top (F) using cage clips every 4 inches. Line door opening by snapping door guards (G) over edges.

7 Slide tray (H) under wire flooring into 3" gap for tray.

Leg Base Kit (OPTIONAL FEATURE)

8 Legs are attached to the bottom unit only. Align tabs on legs so that they straddle the vertical wire on cage that is 1" from cage corner. Leg tabs fit over horizontal bars of cage as shown. Top tabs should slide into horizontal wire on side panel. Using pliers, squeeze top tabs to secure legs in place. To stack cages, simply set another cage on top of the base unit. Secure the cage feet to the lower unit by clipping together at corners. Cages can be stacked up to four levels high.

