

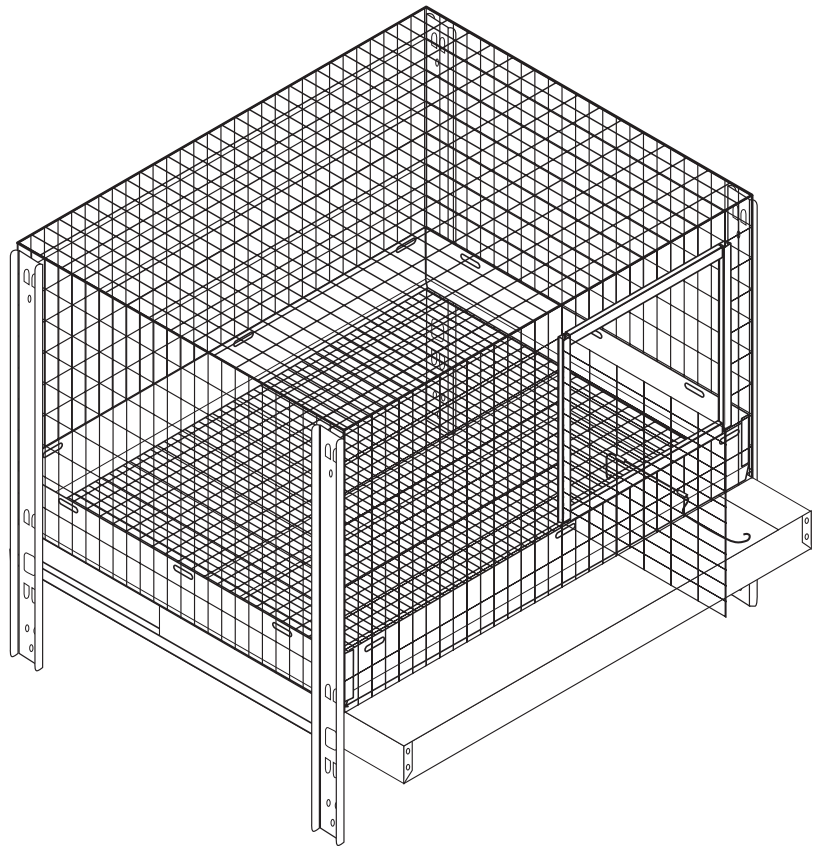

Series 4000

ASSEMBLY INSTRUCTIONS

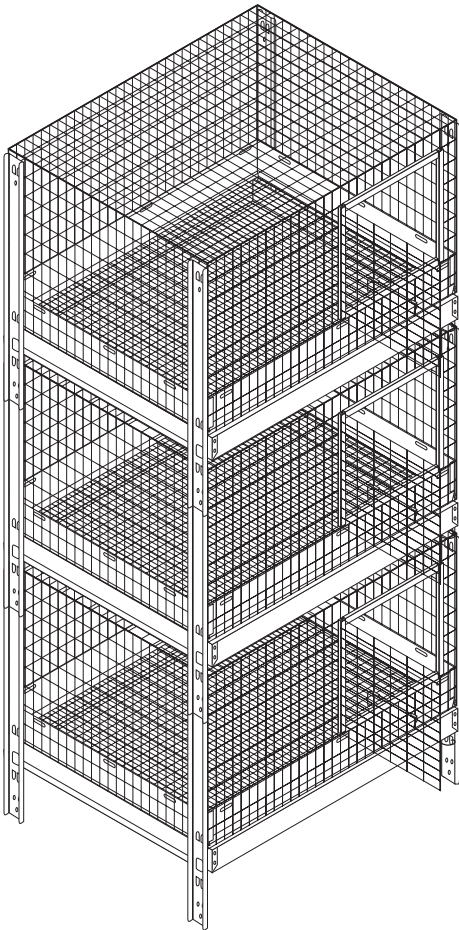

Size

SKU	(L x W x H)	Comps.
4059	30" X 24" X 18"	1
4064	30" X 30" X 18"	1
4039	36" X 30" X 18"	1
4070	36" X 24" X 18"	1
4040	36" X 30" X 18"	2

MADE IN

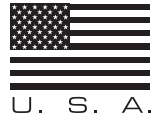

Drawing is representative of most models. Some variations between models may occur.

WARNING



Wire panels and sheetmetal parts may have sharp edges, especially when handled as loose components. Use caution when handling or performing cage assembly and maintenance. Always wear gloves and safety eye-protection to help reduce the chance of personal injury.



Series 4000

ASSEMBLY INSTRUCTIONS

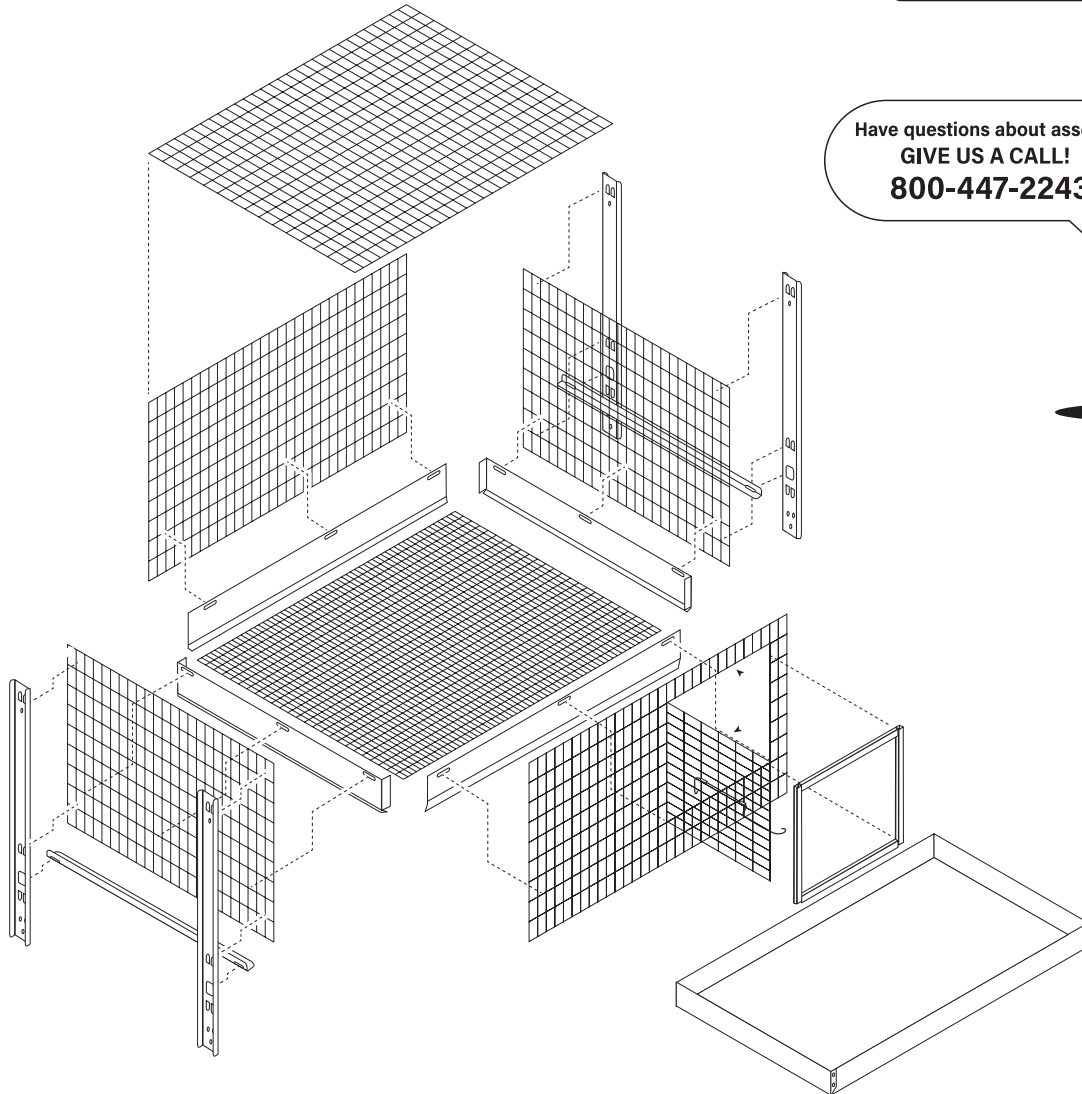

Have questions about assembly?
GIVE US A CALL!
800-447-2243



Part List

Layout and count all parts as shown in the assembly diagram. Notify Customer Service immediately if any parts are missing or damage has occurred during shipment.

Qty	Description	Qty	Description
A	1 Main Panel Sub Assembly	G	4 Leg Support
B	2 Deflector - Side	H	2 Tray Slides
C	2 *Deflector - Front /Back	I	1 Sliding Tray
D	1 Top	J	1 Pack of Cage Clips
E	4 Door Guard	K	Opt. Partition (Model 4040 Only)
F	Opt. Floor Support (Model 4039 Only)	* Model 4040 Has 2 Front / 2 Back Deflectors + a pack of cage rings for partition installation.	



✓ Step-By-Step

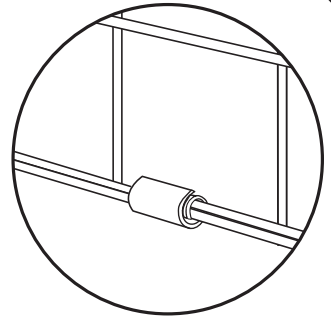
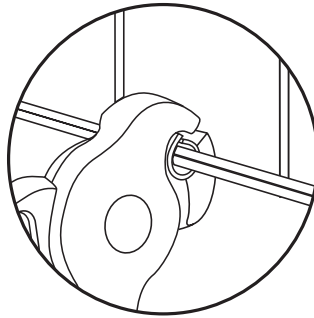
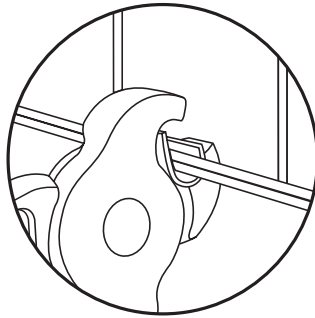
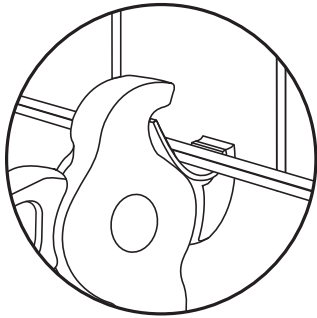

Cage clip pliers are recommended for assembly.

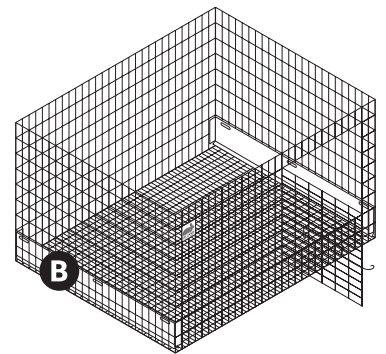
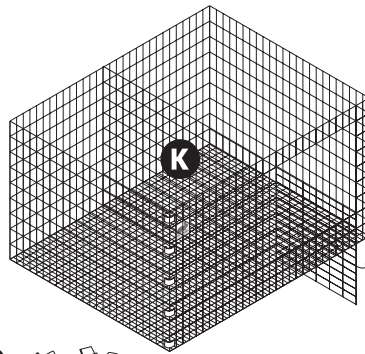
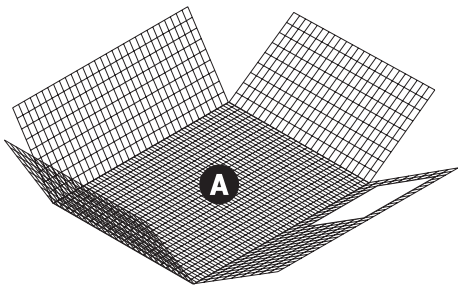

1 Swing sides of panel (A) upward.

2 Attach front, back and side panels using cage clips (J) every four inches. Note: Model 4040 install partition (K) in center of cage from front to back using cage rings.

3 Attach left and right deflectors (B) using one cage clip at each slot.

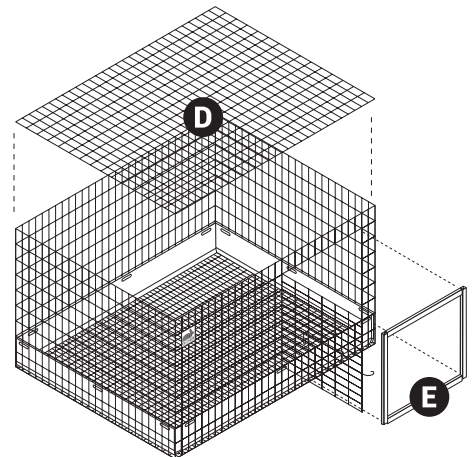
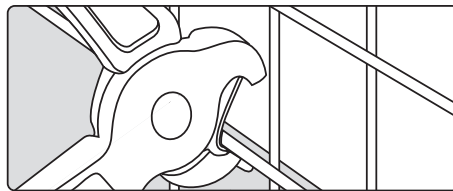
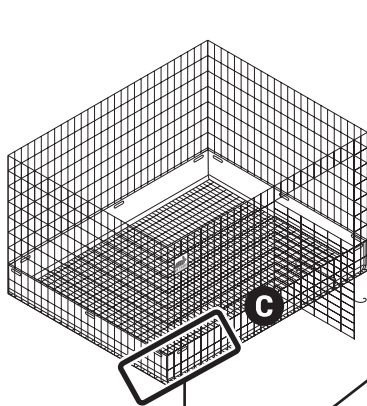

4 Attach front deflector (C) to front panel using cage clips at each slot. Repeat step for back deflector. Note: If center slot is positioned under door opening, leave clip off to attach bottom door guard.

5 Attach top (D) to cage using cage clip every four inches. Snap door guards (E) around edges of door opening. Bottom door guard secures deflector to front panel.



✓ Step-By-Step

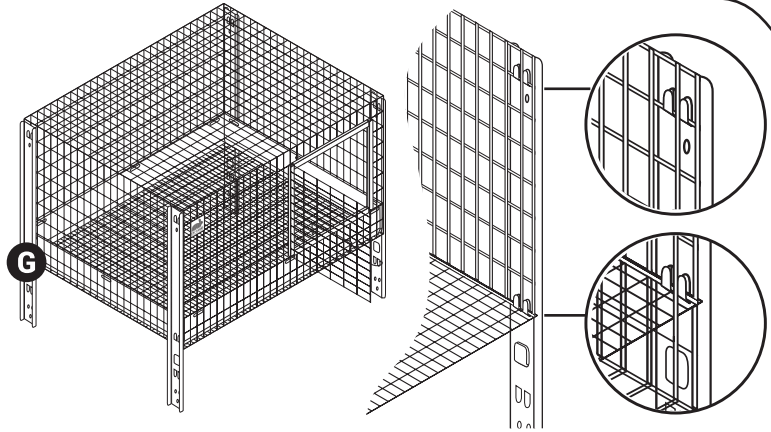
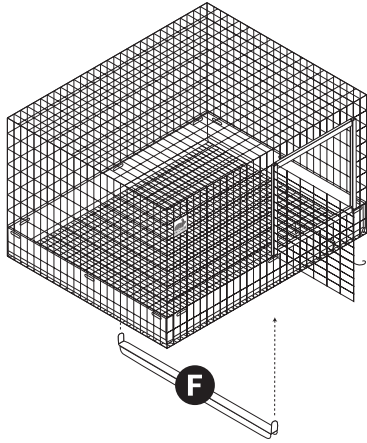

6 (4039 Only) Using pliers, bend tabs of floor support (F) upward as shown until support bracket fits through wire. Bend tabs around flooring and side panel to secure in place. (see diagram below)

7 Align tabs on leg supports (G) so that they straddle the vertical wire on cage that is 1" from cage corner. Leg tabs fit over horizontal bars of cage as shown. Top tabs should slide into horizontal wire on side panel. Using pliers, squeeze top tabs to secure legs in place. Cages can be stacked up to three levels high.

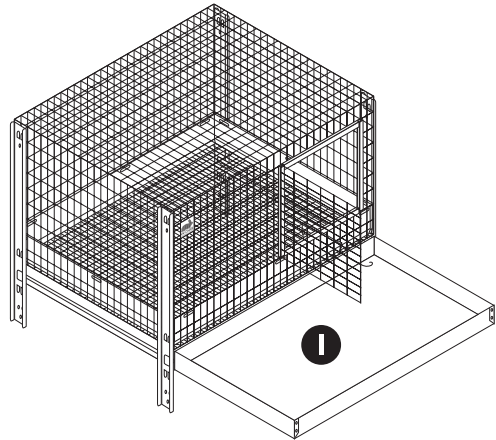
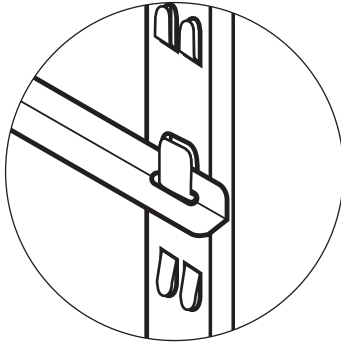
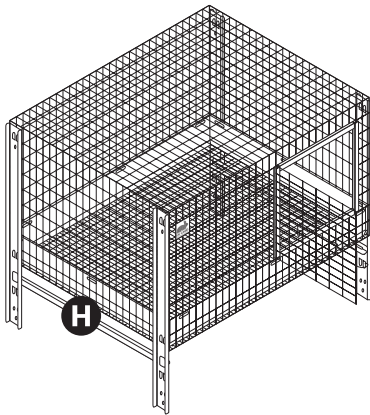

8 Attach slides by positioning cutouts on each tray slide (H) to fit into leg support tabs as shown.

9 Slide tray (I) into opening on top of tray slides.

Floor Support (4039 Only)

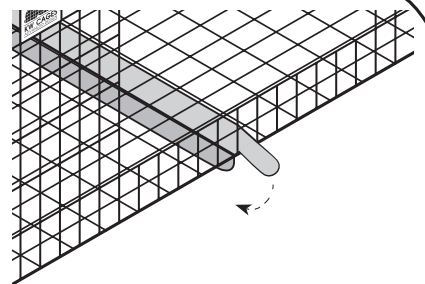
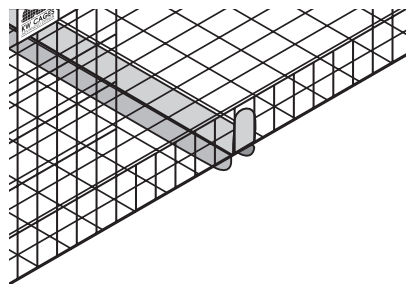
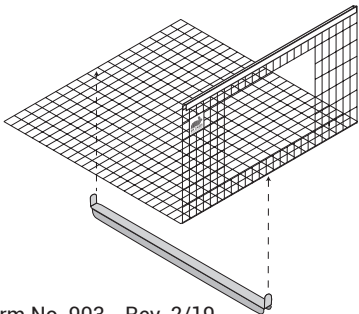



Stacking Units

ASSEMBLY INSTRUCTIONS

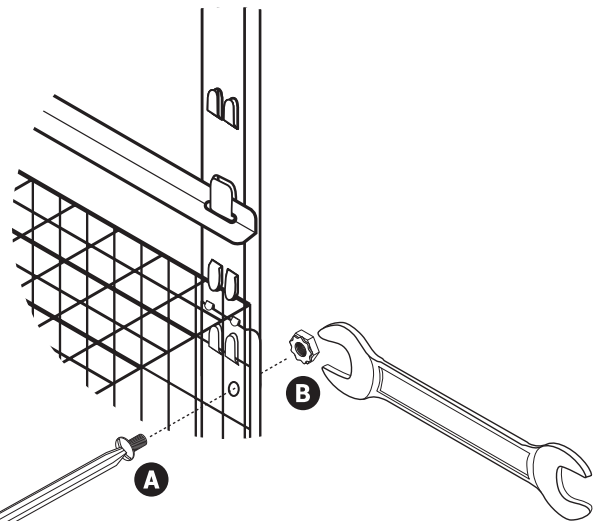
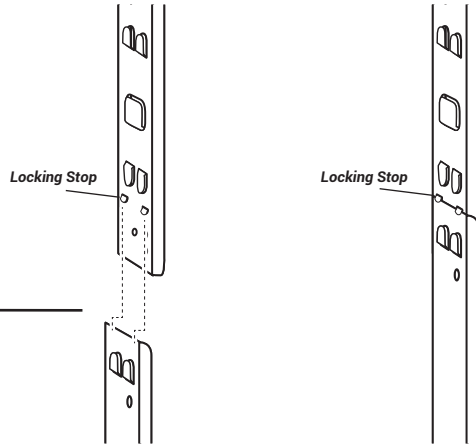
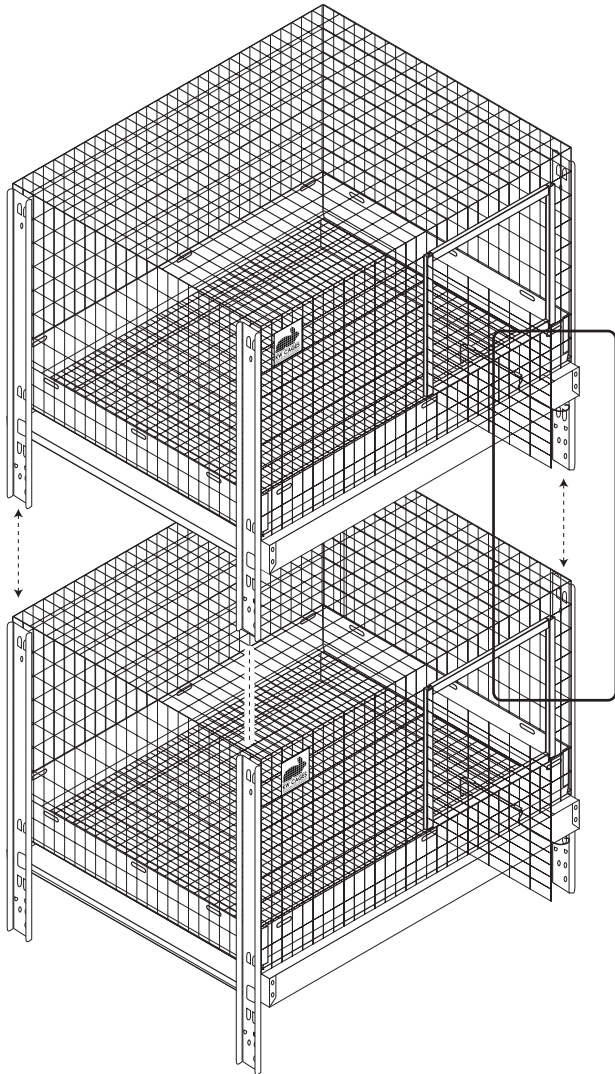

1 Slide legs of top cage into the legs of the bottom cage until each leg is held by the locking stop tabs (as shown below).



Series 4000 cages can be stacked up to three units high.

2 Attach legs together for added stability. Insert flathead screw (A) through pre drilled hole and tighten locking nut (B) on back side, using screwdriver and 7/16" wrench.

Part List

	Qty	Description
 A	4	Flathead Screw
 B	4	Locking nut

Flathead screwdriver & wrench are required for assembly.

WARNING

Use caution when handling or performing cage assembly and maintenance. Always wear gloves and safety eye-protection to help reduce the chance of personal injury.