

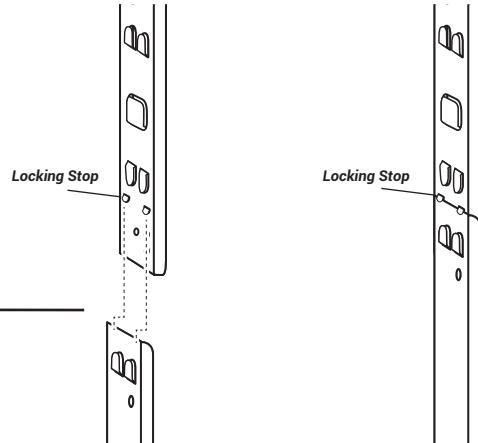

Stacking Units

ASSEMBLY INSTRUCTIONS

1 Slide legs of top cage into the legs of the bottom cage until each leg is held by the locking stop tabs (as shown below).

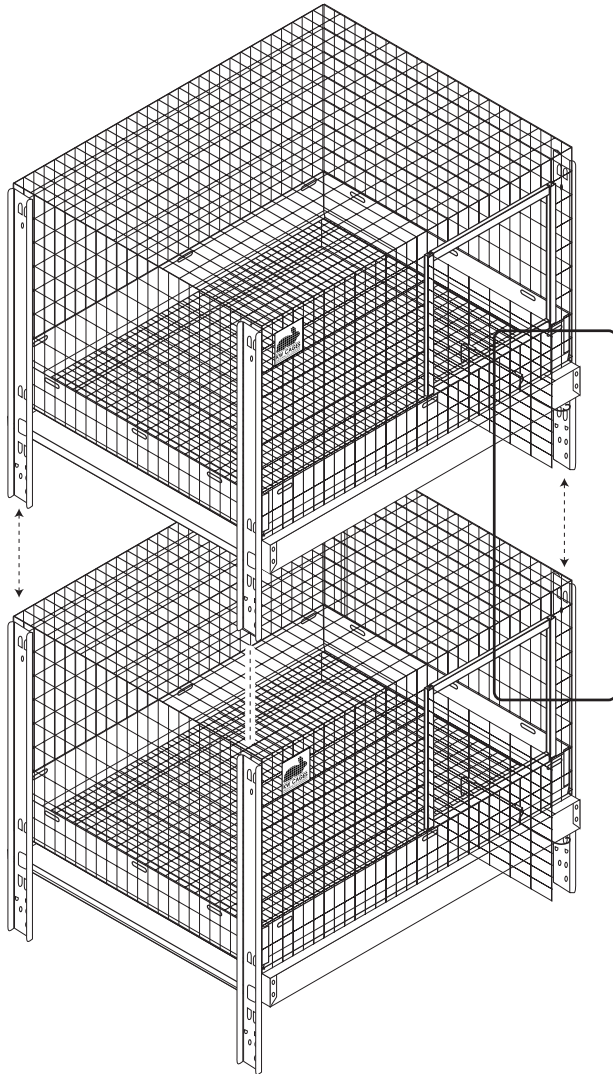

Locking Stop

Locking Stop

Series 4000 cages may be stacked two or three units high.

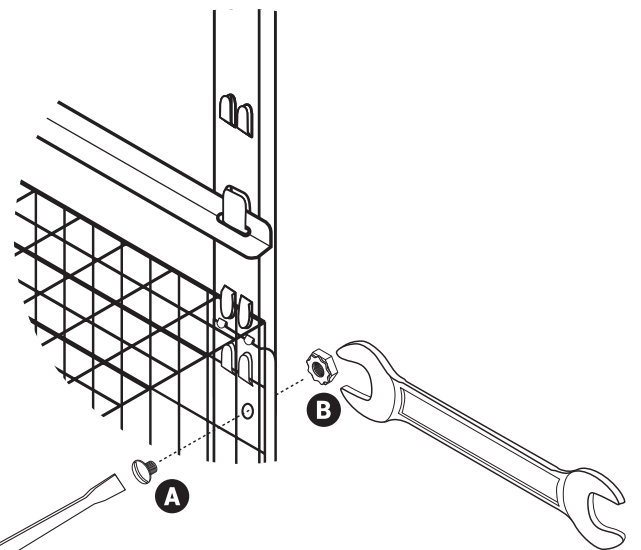

2 Attach legs together for added stability. Insert flathead screw (A) through pre drilled hole and tighten locking nut (B) on back side, using screwdriver and 7/16" wrench.

Part List

Qty	Description
4	Flathead Screw
4	Locking nut

Flathead screwdriver & wrench are required for assembly.



WARNING

Use caution when handling or performing cage assembly and maintenance. Always wear gloves and safety eye-protection to help reduce the chance of personal injury.