

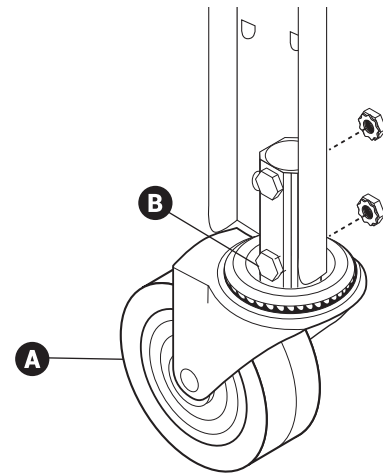

Caster Kit

ASSEMBLY INSTRUCTIONS

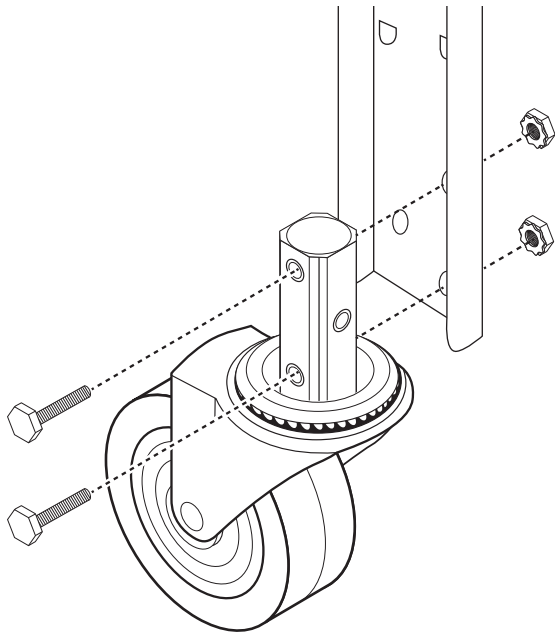

Caster kit attaches to leg supports for added mobility of cages.

1 Insert threaded bolt (B) through pre drilled holes on stem of caster wheel (A).

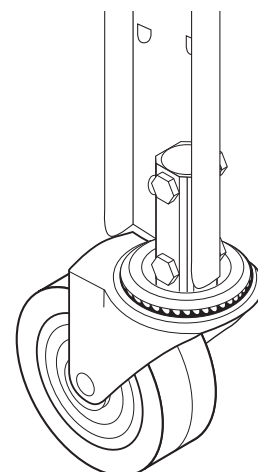
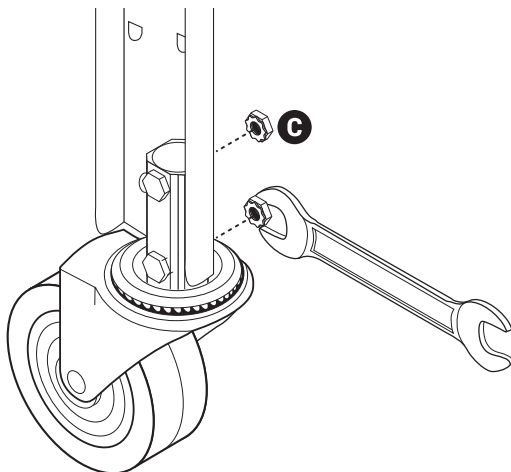

2 Tighten locking nut (C) on back side of leg support using 7/16" wrench

3 For stability be sure caster stems are tightly fastened to cage leg and in a vertical position. Leg extensions must not be used with caster kits.

Part List

7/16" wrench is required for assembly.

	Qty	Description
A	4	Caster wheel / leg assembly
B	8	Threaded Bolt
C	8	Locking Nut

! WARNING

Use caution when handling or performing cage assembly and maintenance. Always wear gloves and safety eye-protection to help reduce the chance of personal injury. Do not use support shelf as a step.