

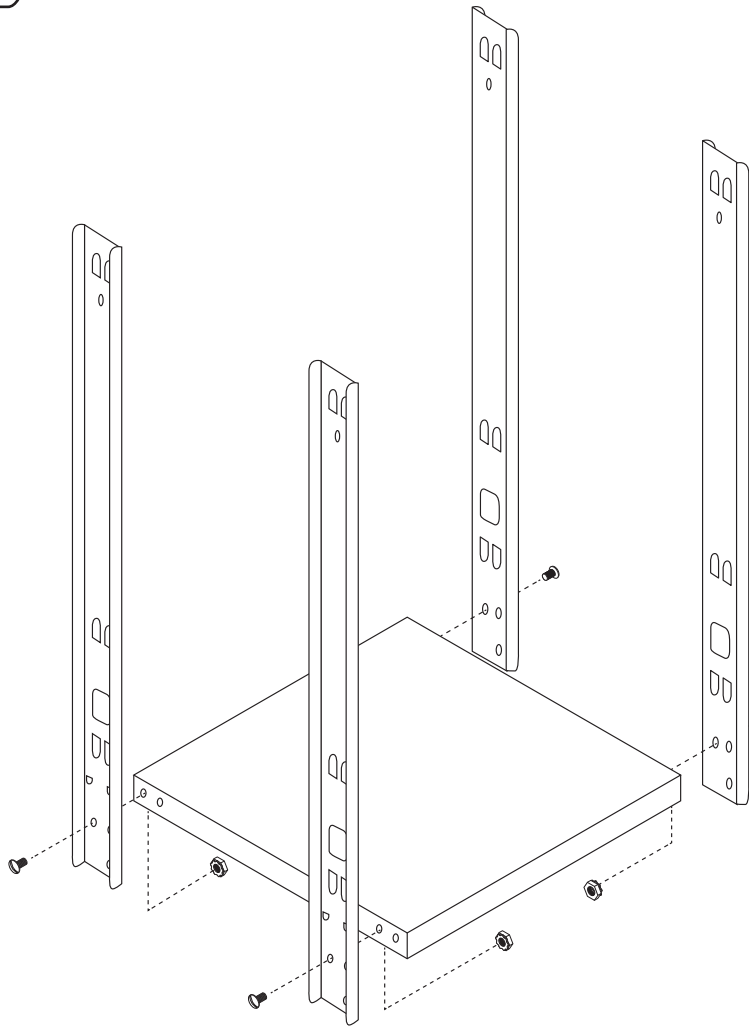

Support Shelf

ASSEMBLY INSTRUCTIONS



1 With support shelf (A) lip facing downward, align holes with upper holes on leg support (B).

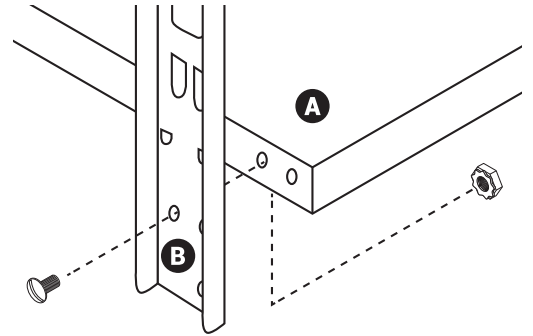

Support shelf is recommended when adding casters to stacked cages and when easily accessible storage is desired.

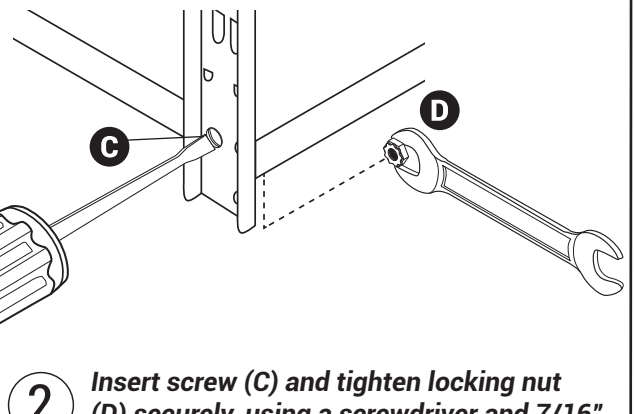

2 Insert screw (C) and tighten locking nut (D) securely, using a screwdriver and 7/16" wrench. Repeat steps to attach each leg to support shelf.

Part List

Qty Description

7/16" wrench and flathead screwdriver are required for assembly.

 A	1	Support Shelf
 B	4	Leg Support
 C	8	Flathead Screw
 D	8	Locking Nut

WARNING

Use caution when handling or performing cage assembly and maintenance. Always wear gloves and safety eye-protection to help reduce the chance of personal injury. Do not use support shelf as a step.