

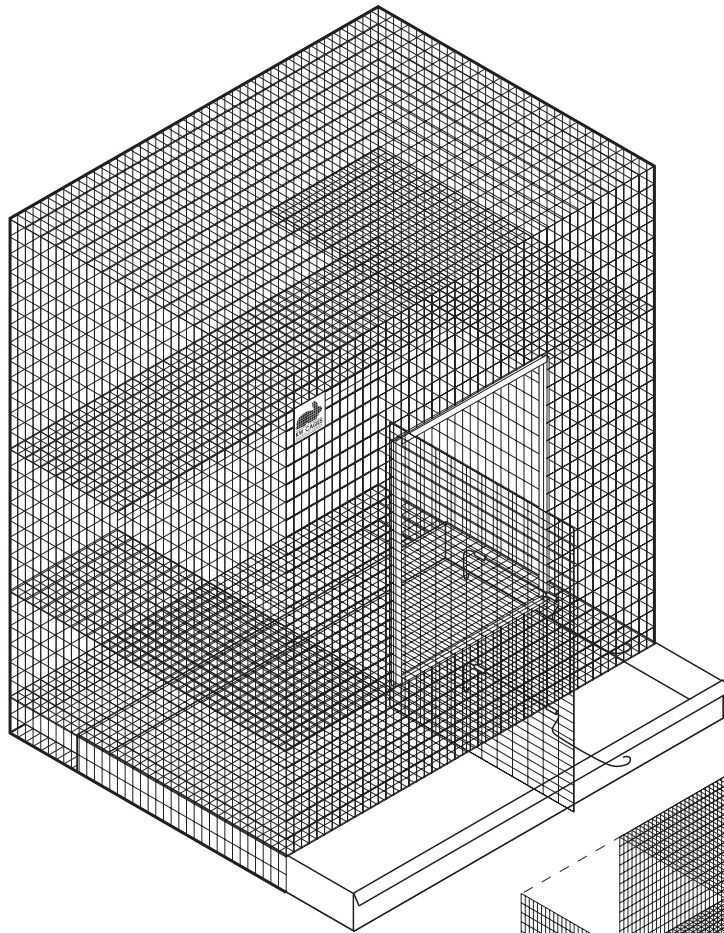

ChinchillaCage

ASSEMBLY INSTRUCTIONS



Have questions about assembly?
GIVE US A CALL!
800-447-2243



Layout and count all parts as shown in the assembly diagram. Notify Customer Service immediately if any parts are missing or damage has occurred during shipment.

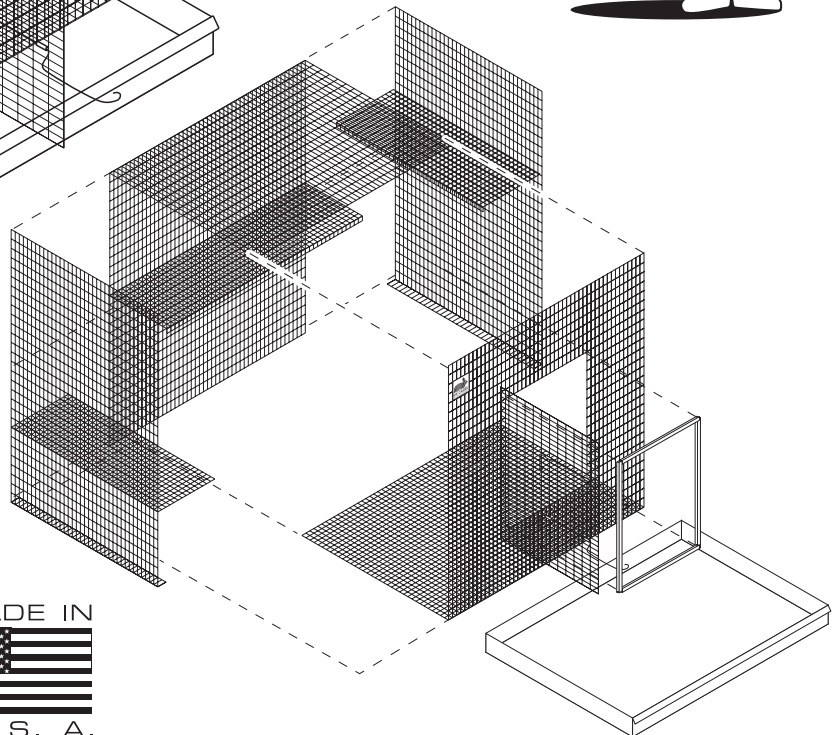

Size

SKU	(L x W x H)
2300	18" X 24" X 29"
2301	18" X 30" X 29"

MADE IN

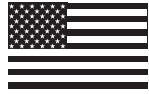

U. S. A.

Drawing is representative of most models. Some variations between models may occur.

WARNING



Wire panels and sheetmetal parts may have sharp edges, especially when handled as loose components. Use caution when handling or performing cage assembly and maintenance. Always wear gloves and safety eye-protection to help reduce the chance of personal injury.



ChinchillaCage

ASSEMBLY INSTRUCTIONS

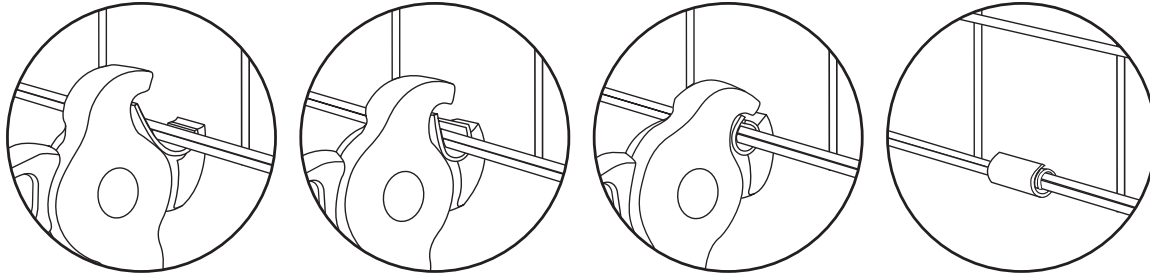

Cage clip pliers are recommended for assembly.

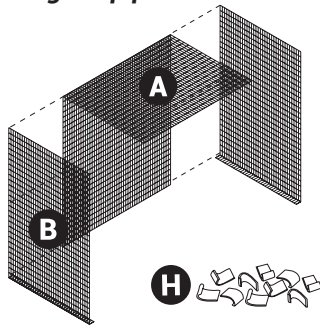

1 Unfold the top/back panel (A) and secure to side panels (B) so that they meet along the edges using cage clips (H) every three inches.

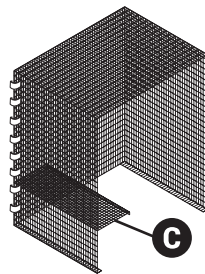

2 Attach small shelf (C) to left side of cage using cage clips. Position long shelf (D) seven inches higher on back panel than left side shelf. Position remaining small shelf on the right panel seven inches higher than previous shelf.

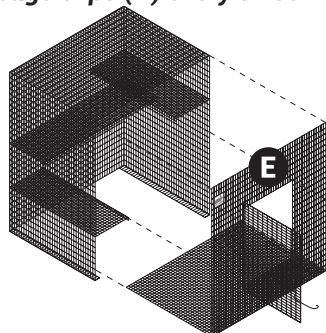
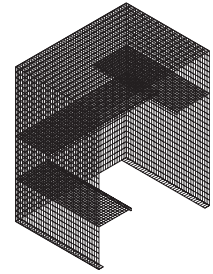
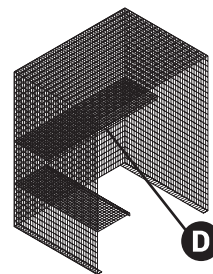

4 Starting from the top, secure the front/floor panel to the cage using cage clips every three inches. There should be a two inch gap under flooring to fit sliding tray into.

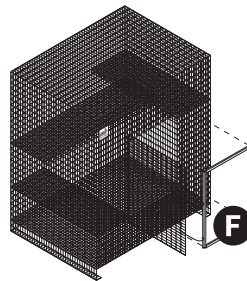



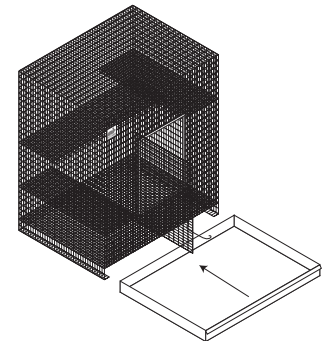



5 Snap door guards (F) around edges of door openings.



6 Slide tray (G) into opening at bottom of cage

Part List

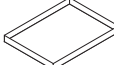
Form No. 913 - Rev. 6/19 © 2019 Kagewerks, Inc.

Qty	Description	Qty	Description
1	 A Top/Back panel	1	 E Floor/Front Panel
2	 B Side Panel Cage Feet	4	 F Door Guard
2	 C Small Shelf	1	 G Sliding Tray
1	 D Large Shelf	1	 H Pack of Cage Clips