

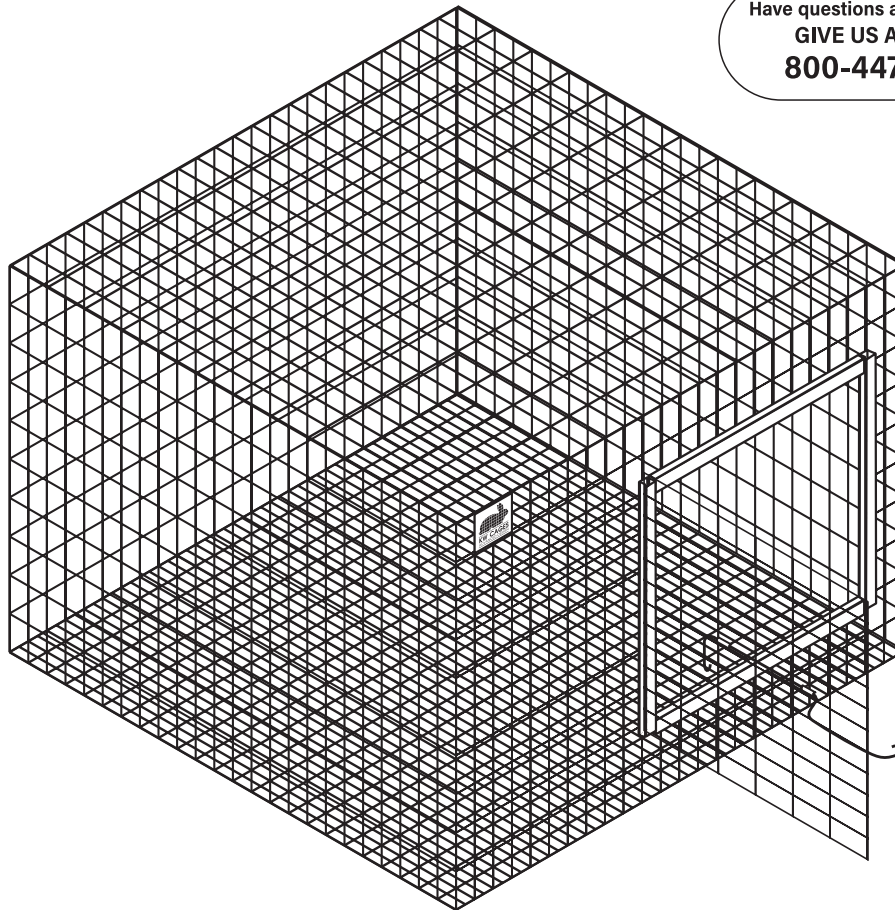

ModularCage

ASSEMBLY INSTRUCTIONS

Have questions about assembly?
GIVE US A CALL!
800-447-2243



Size

Size

SKU	(L x W x H)	Comps.
5026/5226	24" X 18" X 18"	1
5027/5227	24" X 24" X 18"	1
5035/5235	30" X 24" X 18"	1
5036/5236	30" X 30" X 18"	1
5047/5247	36" X 30" X 18"	1
5060/5260	48" X 30" X 18"	1
5067/5267	48" X 24" X 18"	2
5048/5248	36" X 30" X 18"	2

SKU	(L x W x H)	Comps.
5061/5261	48" X 30" X 18"	2
5037/5237	72" X 24" X 18"	3
5081/5281	72" X 30" X 18"	3
5039/5239	96" X 24" X 18"	3
5090/5290	96" X 30" X 18"	3
5038/5238	96" X 24" X 18"	4
5093/5293	96" X 30" X 18"	4
5094/5294	108" X 30" X 18"	6



Drawing is representative of most models. Some variations between models may occur.

WARNING



Wire panels and sheetmetal parts may have sharp edges, especially when handled as loose components. Use caution when handling or performing cage assembly and maintenance. Always wear gloves and safety eye-protection to help reduce the chance of personal injury.



ModularCage

ASSEMBLY INSTRUCTIONS

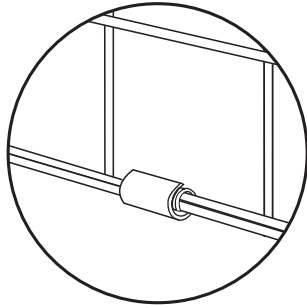
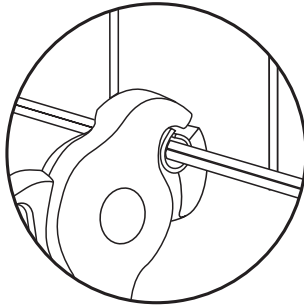
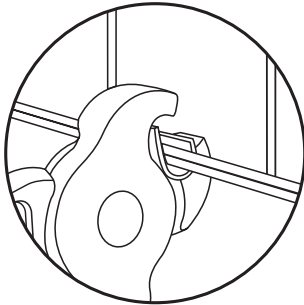
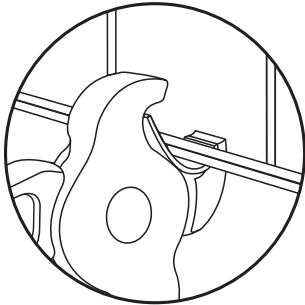

Cage clip pliers are recommended for assembly.

Which compartment configuration do you have?

This assembly guide is meant to show the concept of how each modular cage is assembled.

Overall dimensions may vary depending on the specific cage you are assembling.

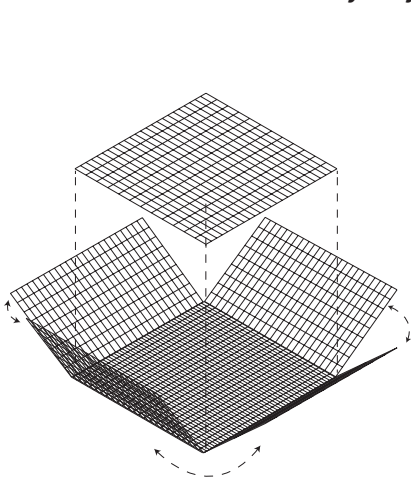

A Single Section Cage

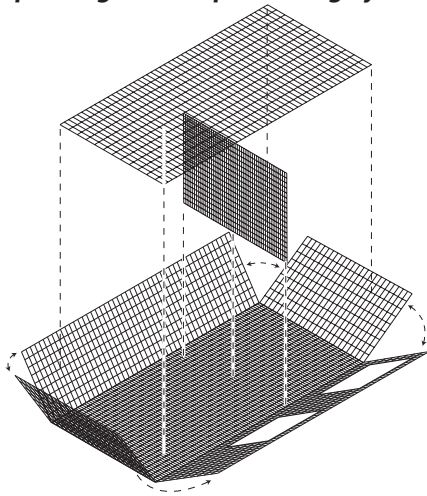

B Single Section Cage With Divider(s)

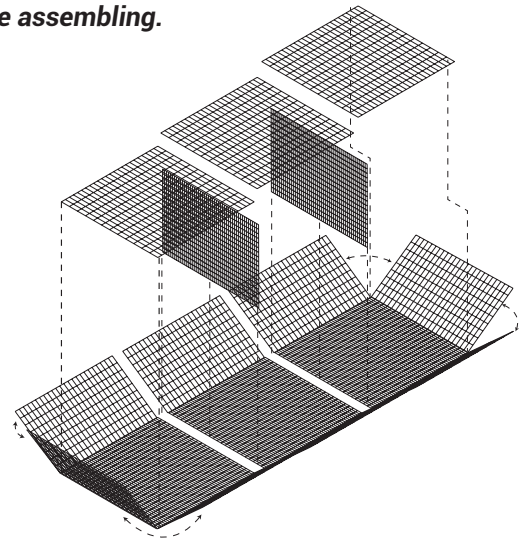

C Multi Section Cage With Divider(s)

A Single Section Cage

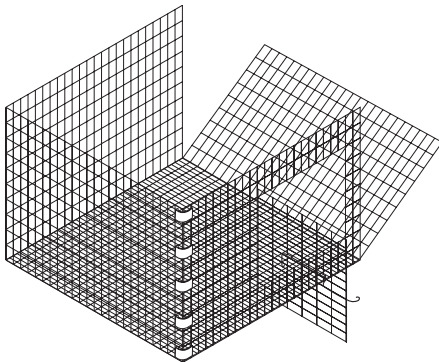

1 *Unfold the pre-assembled section. Set it up so that each panel meet at the corners. Secure corners with cage clips every four inches.*

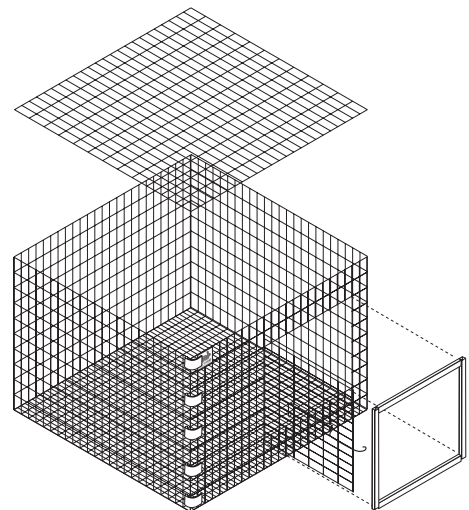

2 *Attach top panel to body of cage using cage clips every four inches. Snap door guards around edges of door openings. Cage is assembled and ready for use.*



ModularCage

ASSEMBLY INSTRUCTIONS

B Single Section Cage With Divider(s)

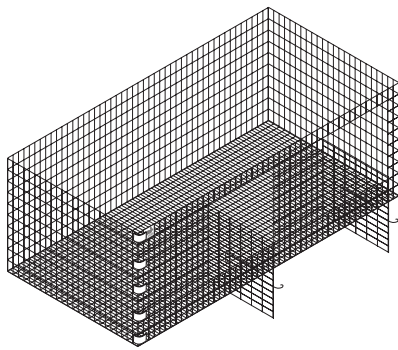

1 *Unfold the pre-assembled section. Set it up so that each panel meet at the corners. Secure corners with cage clips every four inches.*

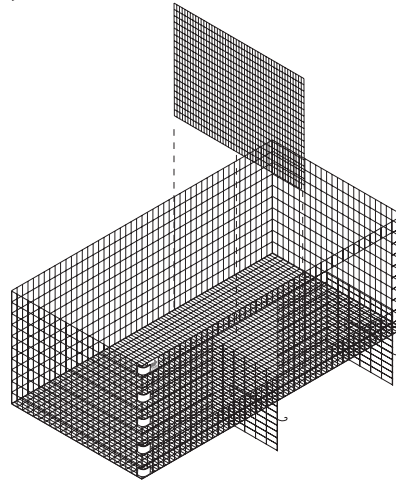

2 *Attach partition in center of section using cage clips every three inches.*

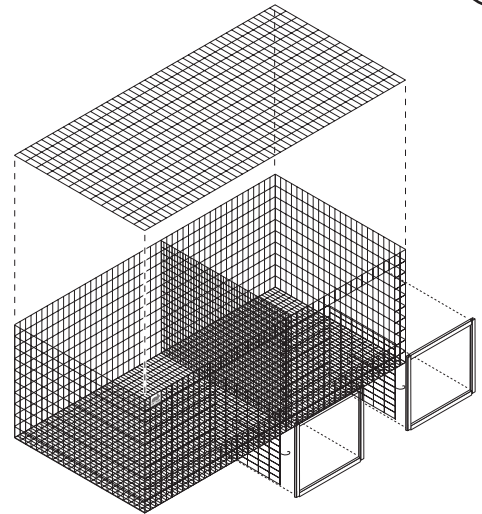

3 *Attach top panel to body of cage using cage clips every four inches. Snap door guards around edges of door openings. Cage is assembled and ready for use.*

C Multi Section Cage With Divider(s)

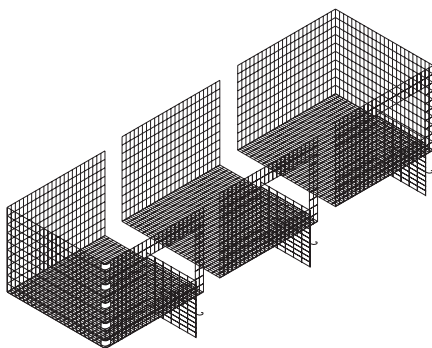

1 *Unfold the pre-assembled section. Set it up so that each panel meet at the corners. Secure corners with cage clips every four inches.*

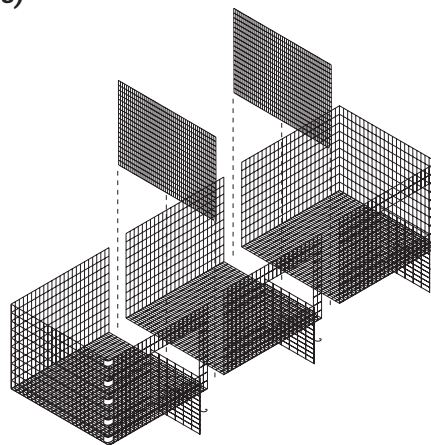

2 *Attach partition in center of section using cage clips every three inches.*

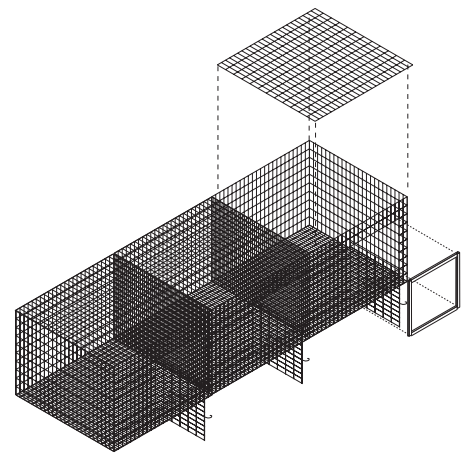

3 *Attach top panels to body of cage using cage clips every four inches. Snap door guards around edges of door openings. Cage is assembled and ready for use.*