

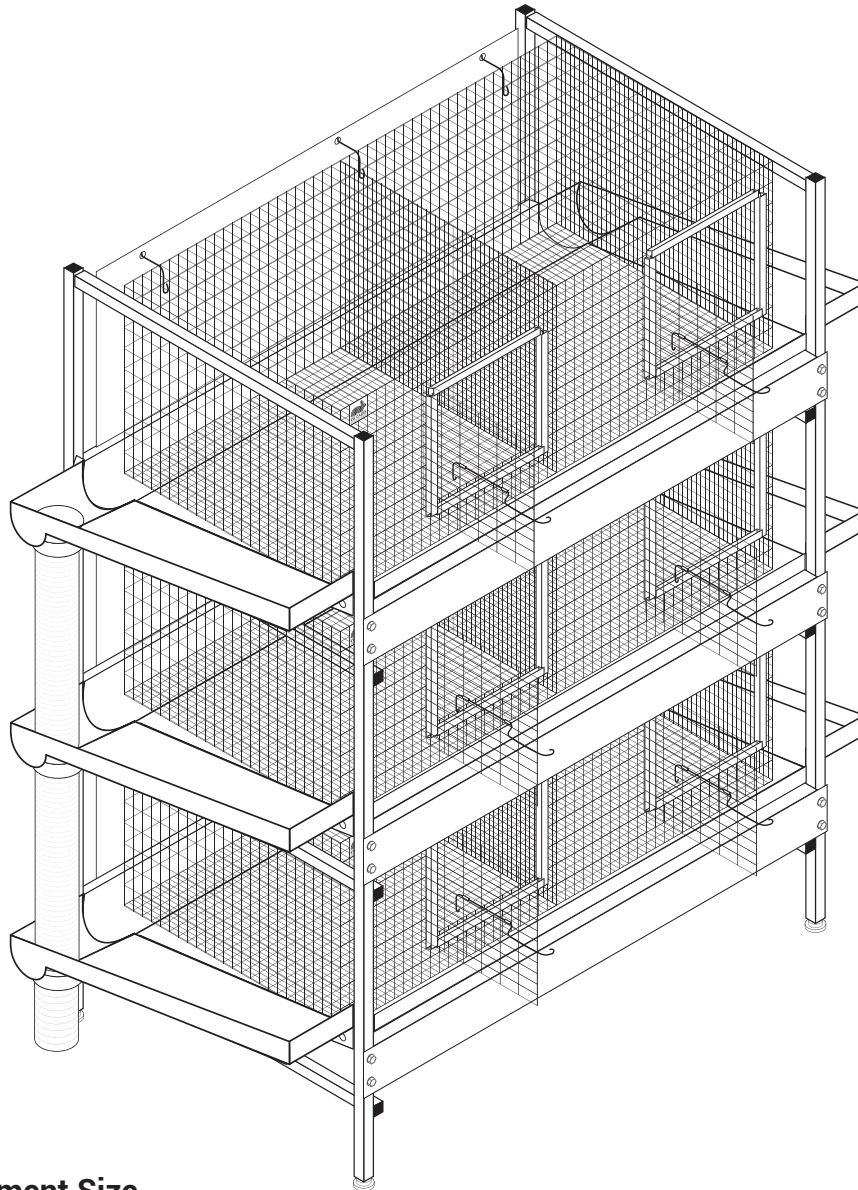

Rabbitech™

ASSEMBLY INSTRUCTIONS



Compartment Size

SKU	(L x W x H)	Comps.
5530	48" X 24" X 14"	3
5532	24" X 24" X 14"	6
5534	16" X 24" X 14"	9

Tri-Level Starter
Overall Dimensions: 60" x 36" x 75"

Drawing is representative of most models. Some variations between models may occur.

WARNING



Wire panels and sheetmetal parts may have sharp edges, especially when handled as loose components. Use caution when handling or performing cage assembly and maintenance. Always wear gloves and safety eye-protection to help reduce the chance of personal injury.



Rabbitech™

ASSEMBLY INSTRUCTIONS

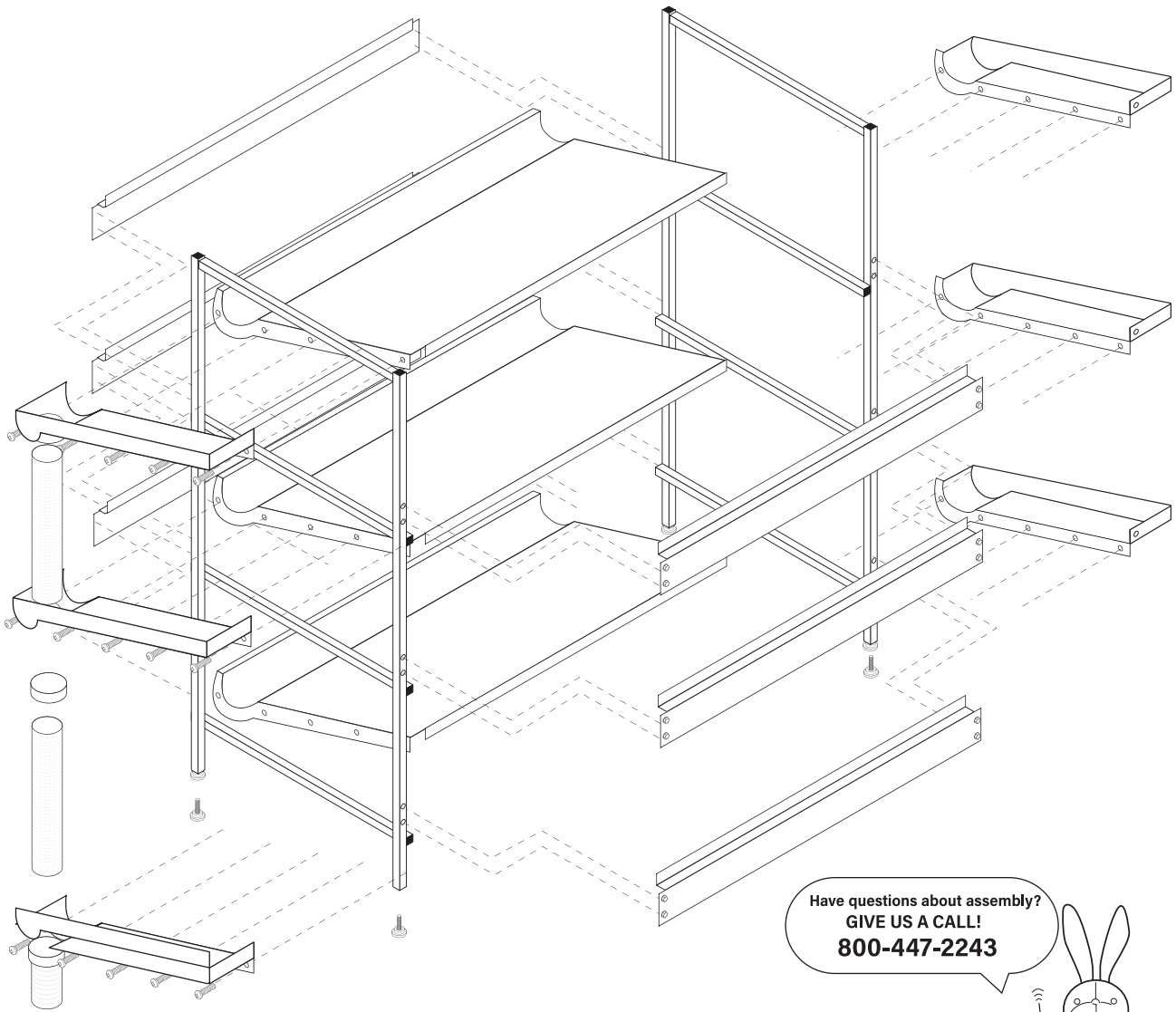

Have questions about assembly?
GIVE US A CALL!
800-447-2243



Tools Required

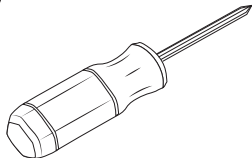

Phillips Screwdriver

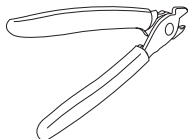

Ring Pliers

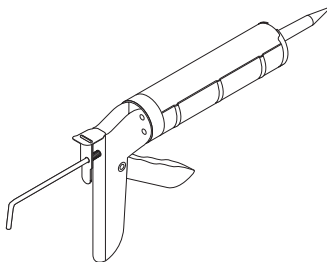

Caulking Gun

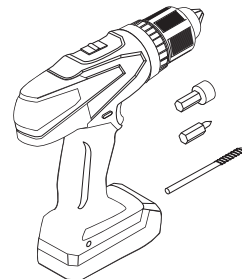

Drill Driver with:
3/8" Hex Bit
9/32" Drill Bit
Phillips Bit

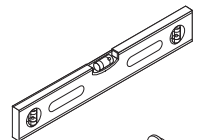

Helpful Tools
(Not Required)
Carpenter's Level
C-Clamps

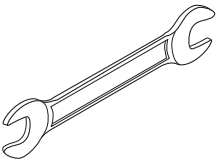

7/16" Wrench



Clip Pliers











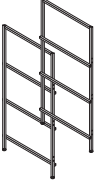
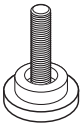
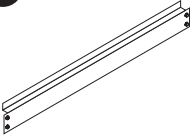

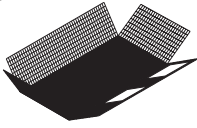
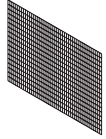
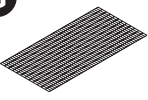
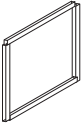

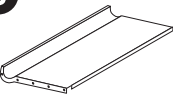

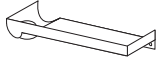
Rabbitech™

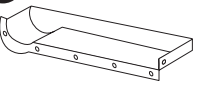
ASSEMBLY INSTRUCTIONS

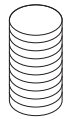
Starter Kit Part List

Layout and count all parts as shown in the assembly diagram. Notify Customer Service immediately if any parts are missing or damage has occurred during shipment.

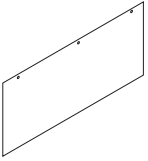
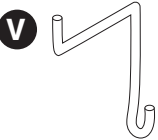
H-Frame	Leveling Foot	Support Beam	SS Hex Tech Screw	Partially Assembled Cage Panels	Partition
A 	B 	C 	D 	E 	F 
					Compartments
					3 6 9
2	4	6	16	1	0 1 2
Cage Wire Top	Door Guards	Clips	Wash-Down Pans	Cage Clamp	End Cap w/ Drain
G 	H 	I 	J 	K 	L 
-	Compartments	-	-	-	-
-	3 6 9	-	-	-	-
1	12 24 36	1/2LB.	3	12	3
SS Bolt	SS Nut	End Cap w/o Drain	Silicone (Tube Only)	Short Drain Pipe	Long Drain Pipe
M 	N 	O 	P 	Q 	R 
36	36	3	1	1	2
SS PhillipsTech Screw	Washer	Back Splash	Wire Holder		
S 	T 	U 	V 		
12	12	3	9		



✓ Step-By-Step Frame Assembly

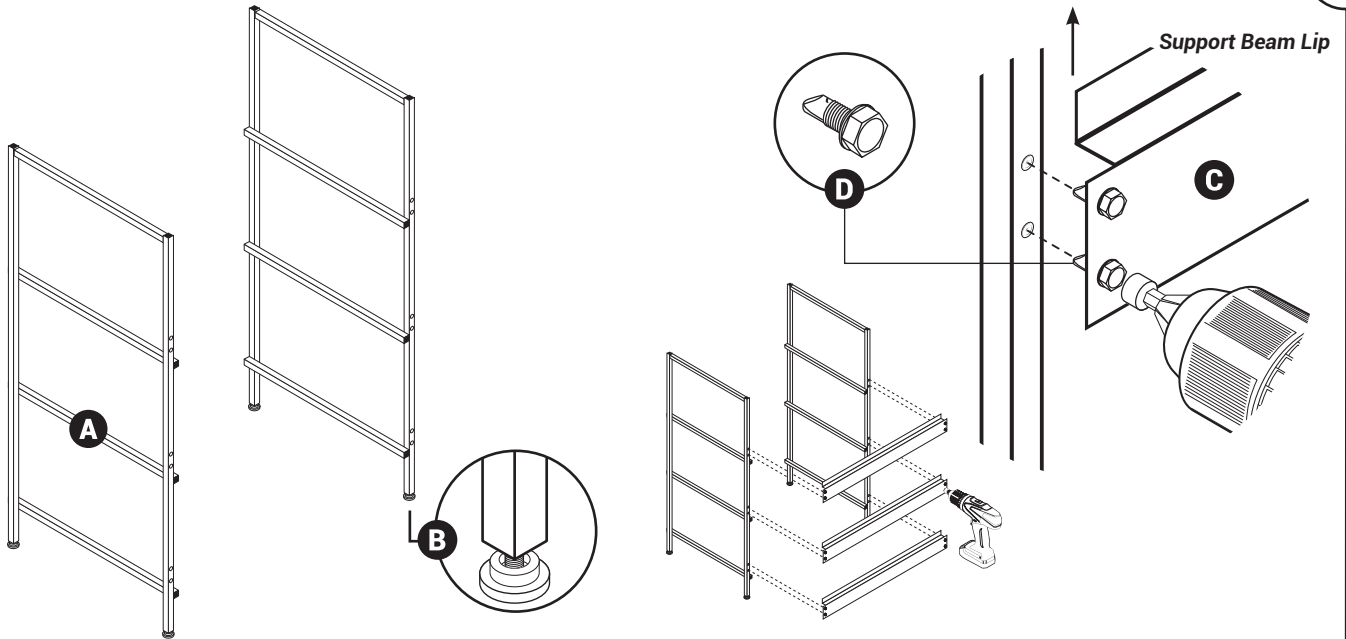

1 Attach self leveling feet (B) to the bottom of each H-frame (A). Adjust leveling feet to be approx. 1/8"-1/4" longer for each successive section.

2 Position support beam (C) to span across both H-Frame sections. Attach support beam so that lip faces upward to support plastic wash-down pan. Align holes in support beam with dimples in H-Frame. Using drill with 3/8" hex bit to drive stainless steel self drilling screws (D) into dimple. Apply moderate pressure. Repeat on opposite side until all six beams are attached.

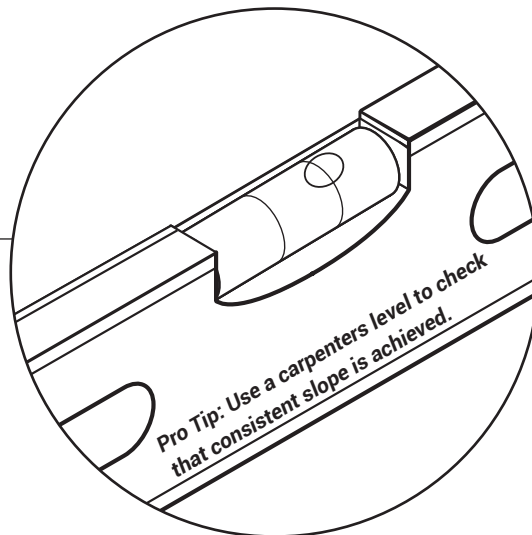
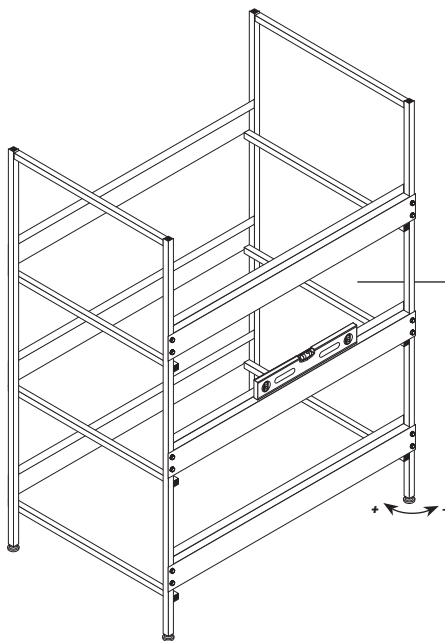

3 Adjust all leveling feet such that each frame is a minimum of 1/8" taller than the preceding frame. See step one for detail. A carpenters level can be used to check for consistent slope by maintaining the bubble slightly off of center. This will ensure proper drainage toward the lower drain side when cleaning the Rabbitech System. If add-on kits are installed, make sure to maintain the proper slope as units are added for optimal drainage. If floor of building is not level more or less adjustment may be required.



✓ Step-By-Step Cage Assembly

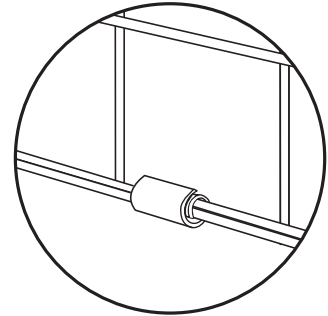
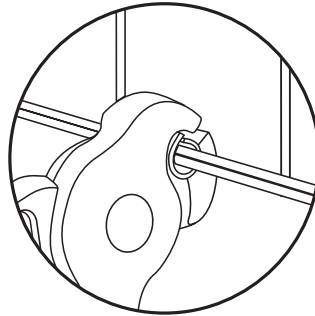
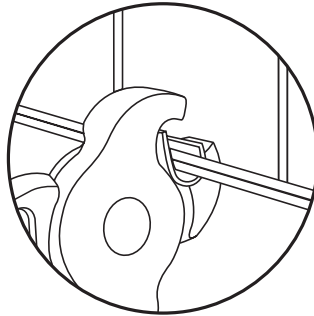
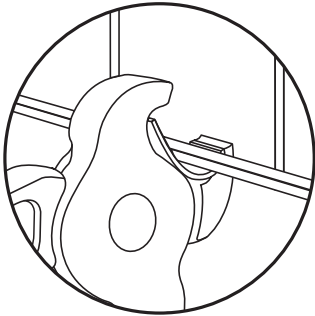

Cage clip pliers are recommended for assembly. Ring pliers for partitions are recommended.

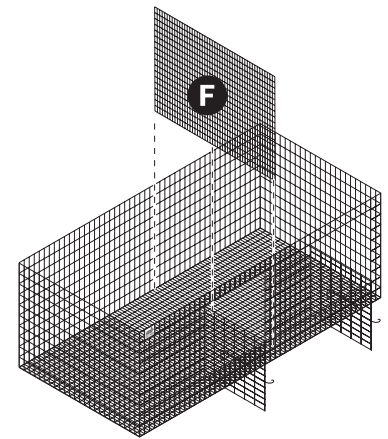
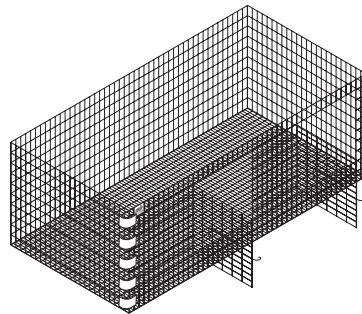
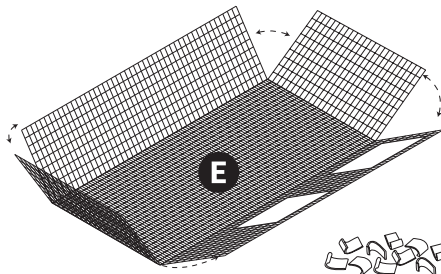

4 Unfold main panel sub assembly (E) so that each side panel meet at the corners.

5 Attach front, back and side panels using cage clips (I) every three inches.

6 IF you ordered a Rabbitech sytem that has multiple compartments, secure the partition (F) centered on the inside of cage or divided into thirds. Use cage clips on the front and back panel every three inches.

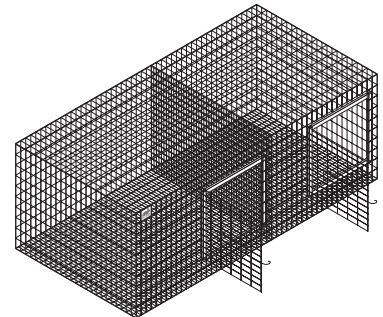
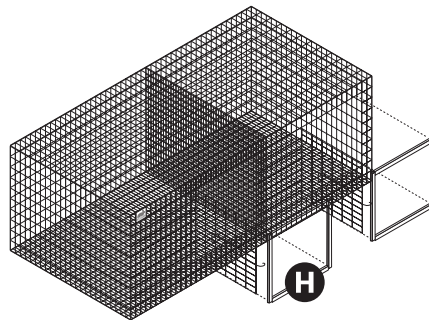
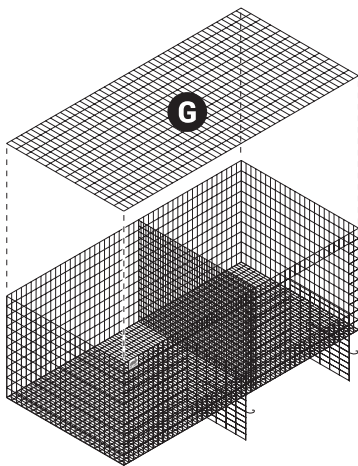

7 Attach top of cage (G) using cage clips every two inches around the perimeter of the cage.

8 Snap door guards (H) around edges of door opening. Repeat steps for all door openings.

9 Repeat steps until both all levels of cages are assembled.



✓ Step-By-Step

Drilling Holes For Proper Alignment

Why are holes only on one side of the pan?

One side is used as the guide to drill into the adjoining pan. This ensures perfect alignment every time.

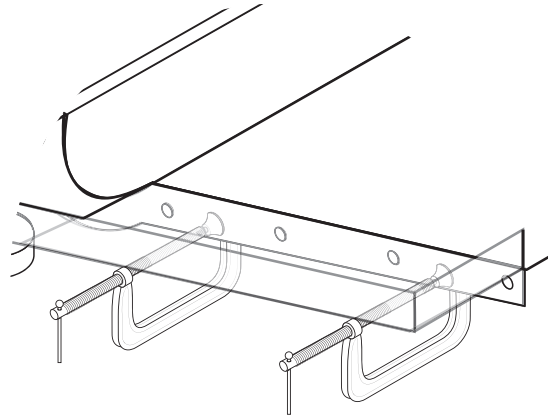
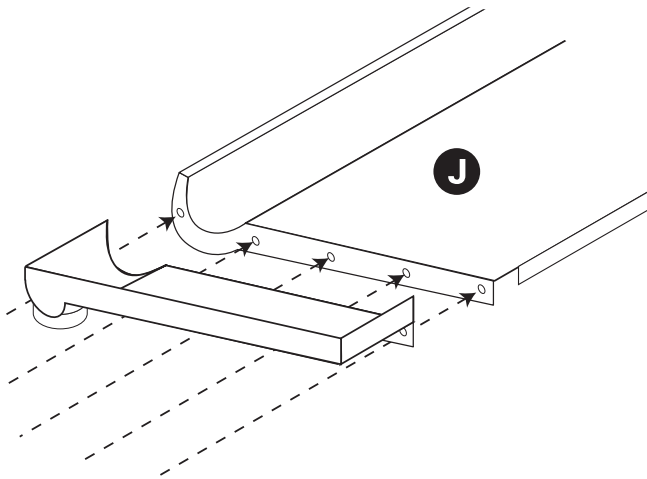

10

Place wash down pan (J) into frame. Carefully align edge of end cap with pre drilled holes to edge of pan without holes. Use the pre drilled holes as a template of where to drill holes into the wash down pan. Be sure to keep both pieces secured in place as holes are drilled to ensure proper alignment when assembling pans to end caps. We recommend using c-clamps or spring clamps to minimize any shifting that may occur. Once holes have been drilled, set end cap aside for further instruction on when to attach to wash down pan.

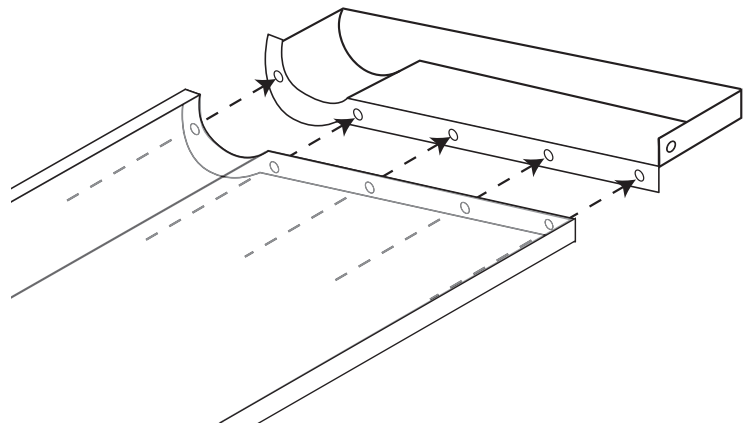
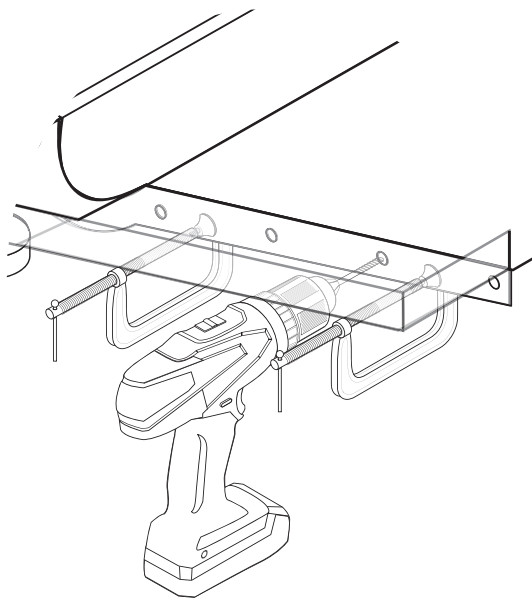

11

Press firmly with drill using pre drilled holes as a guide. Repeat step until all holes have been drilled. The end cap and wash down pan holes should match.

12

Repeat steps for the remaining sides. You may need to lay down under the frame to achieve the proper angle. Use the holes on the wash down pan as a template to drill through the side of the end cap. Once holes are drilled, set end cap aside for further instruction.



✓ Step-By-Step

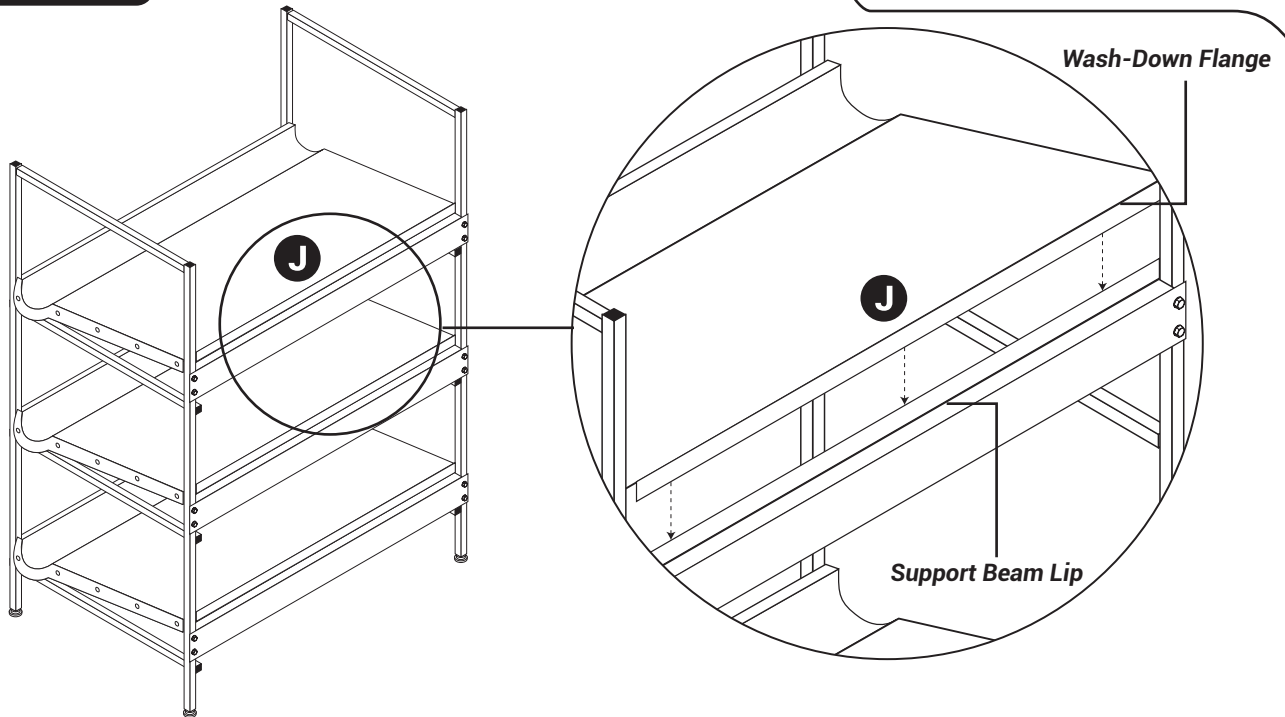

- 13** Set a wash-down pan (J) into the top into the top frame so that front and back flanges rest over support beam lips. Bottom of gutter flange will rest on top of H-Frame cross bar. No additional attachment to frame is necessary.

Installing Add-Ons

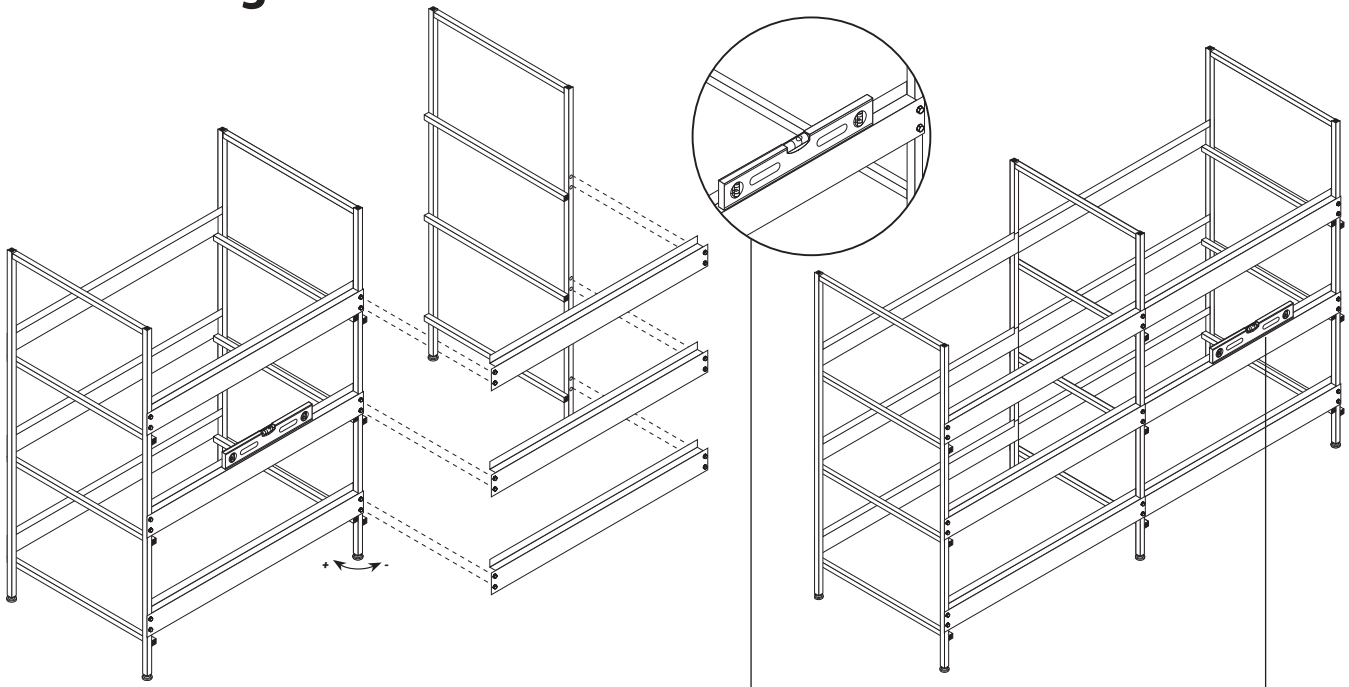

- 14** To add the next H-Frame to the row, align holes in support beams with dimples in H-Frame. You may need to remove screws since center H-Frame shares the same pair of holes to attach support beams. Drive stainless steel self drilling screws (D) into dimples. Repeat on opposite side until all add-on support beams are attached. Once all support beams are attached, adjust leveling feet so that each frame is a minimum of 1/8"-1/4" taller than the preceding frame.



✓ Step-By-Step Sealing Multiple Units

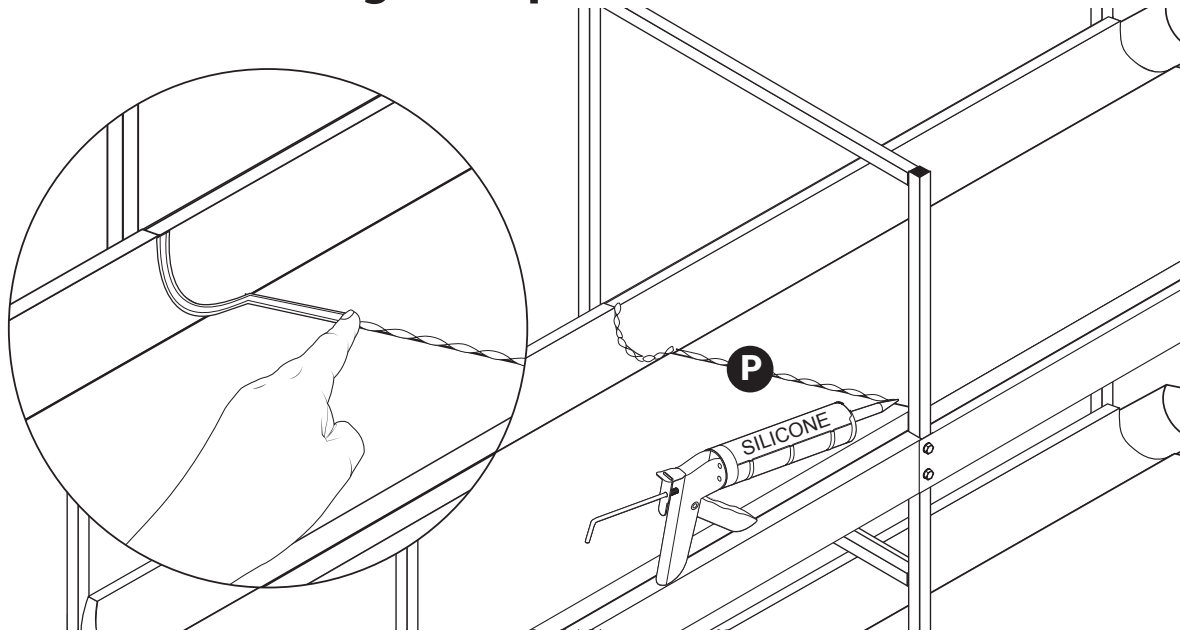

- 15** To make water tight, use the silicone provided (P) to seal along the groove where the two pans meet. Caulking should be smoothed with a fingertip. Dip finger in water for a smooth joint. Use a rag to wipe excess caulking from finger. Seal all levels of the Rabbitech system **BEFORE** cages are installed. Allow a minimum of 24 hours for caulking to set and cure before testing for leaks. **DO NOT** attach end caps until **AFTER** cages are installed.

Attaching Cages to Frame

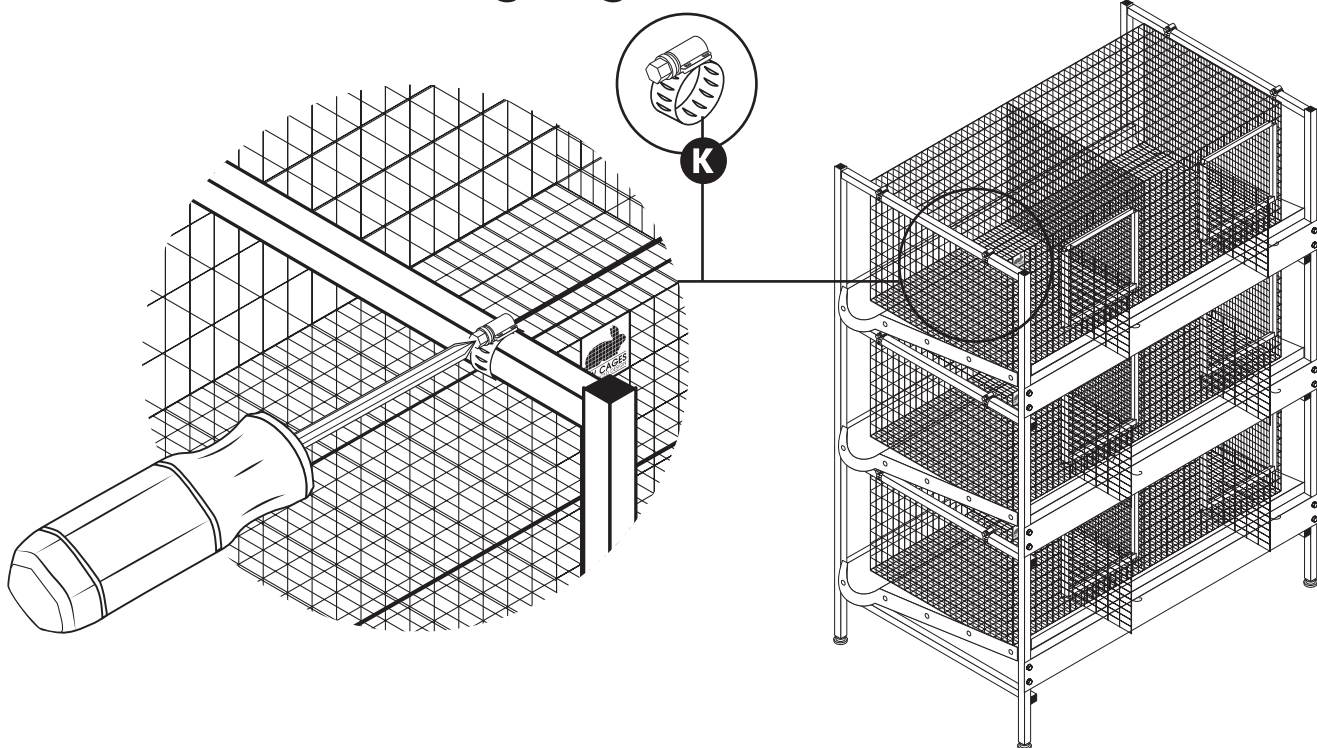

- 16** Once cages are fully assembled, they may be positioned and hung under H-frame cross bars using cage hanging clamps (K). Cardboard (or equivalent) can be placed across wash-down pans to serve as a sled to slide the cage sections into place. Tip: A long 1x4 board can be used to span the plastic pan and lift cages into place. Once cages are positioned, use cage hanging clamps to secure cage to H-frame.



✓ Step-By-Step Attach End Caps

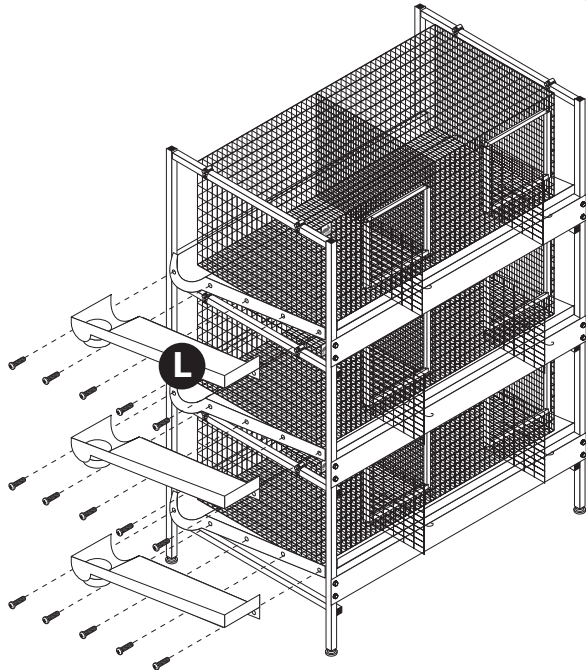

M



N

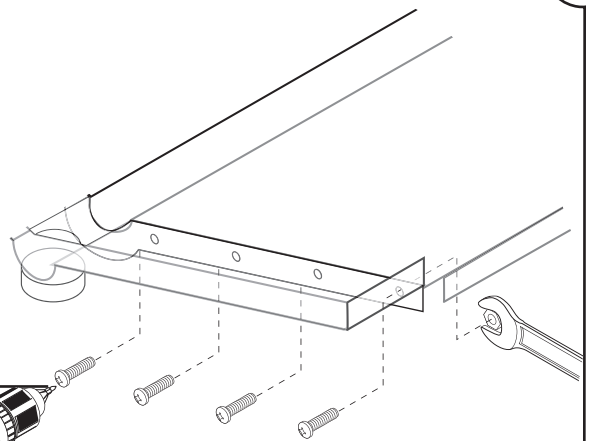
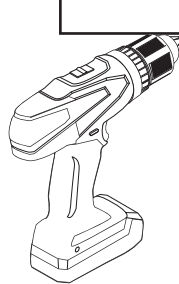

- 17** Attach lower side end cap w/ drain (L) to wash-down pan. Align end cap with wash-down pan holes. Use the provided SS Phillips Screw (M) and SS Nut (N) tighten until snug using a screwdriver and wrench. Make sure end caps with down drain holes are level or slightly lower than top surface of the wash-down pan to ensure proper water flow from high to low.

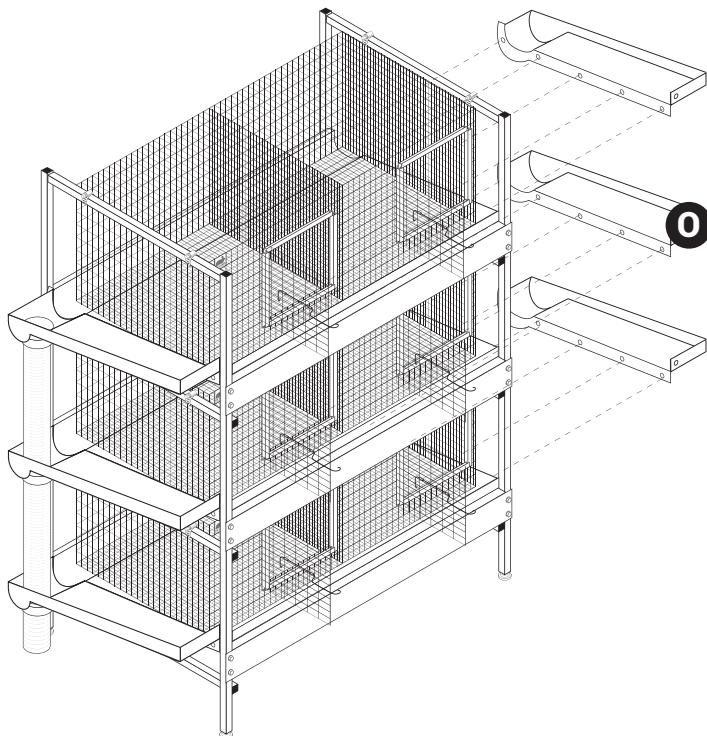

Seal End Caps

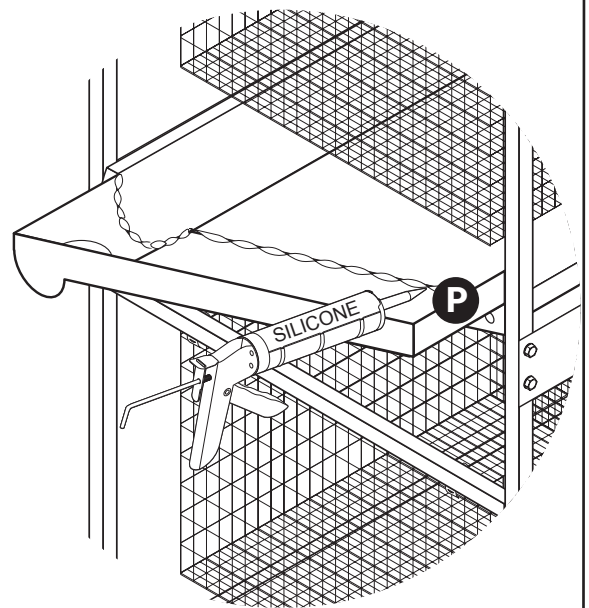

- 18** Repeat step 12 for high side end caps w/o drain (O). Make sure end caps (without drain) sits flush or slightly higher than the wash-down pan to ensure proper drainage from the high to low side of the system when cleaning.

- 19** Using a caulking gun, apply a bead of silicone (P) along the valleys where the end cap meets the wash-down pan.



✓ Step-By-Step

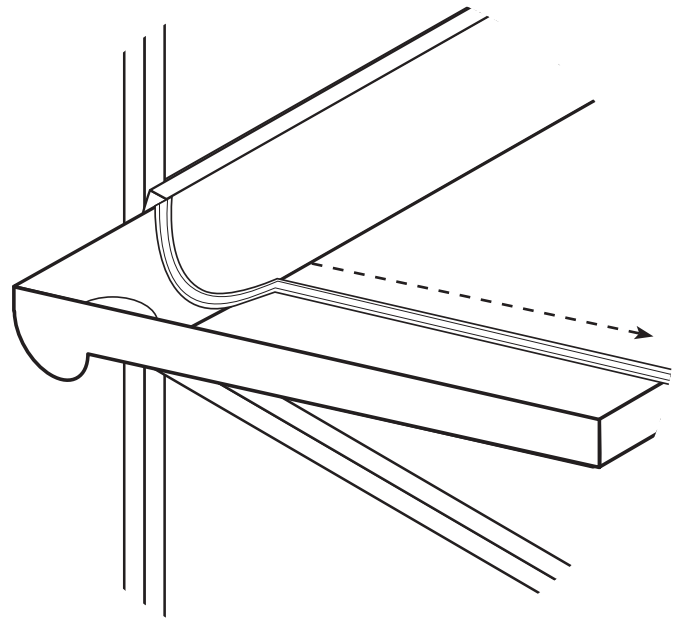
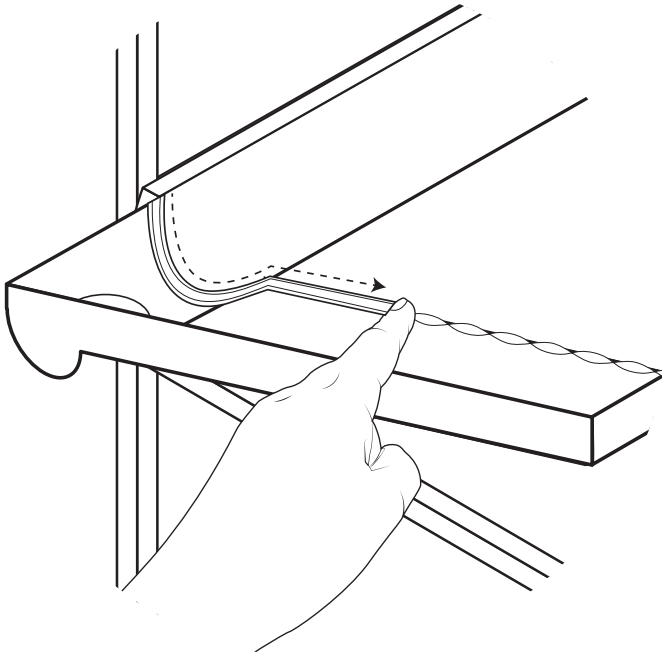

20 *Caulking should be smoothed with a fingertip. Dip finger in water for a smooth joint. Use a rag to wipe excess silicone from finger. Allow a minimum of 24 hours for caulking to set and cure before testing for leaks.*

Connecting End-Drain Pipes

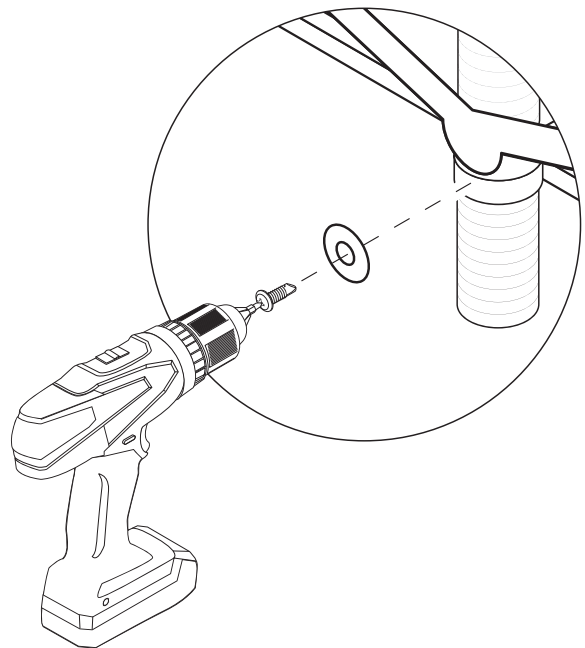
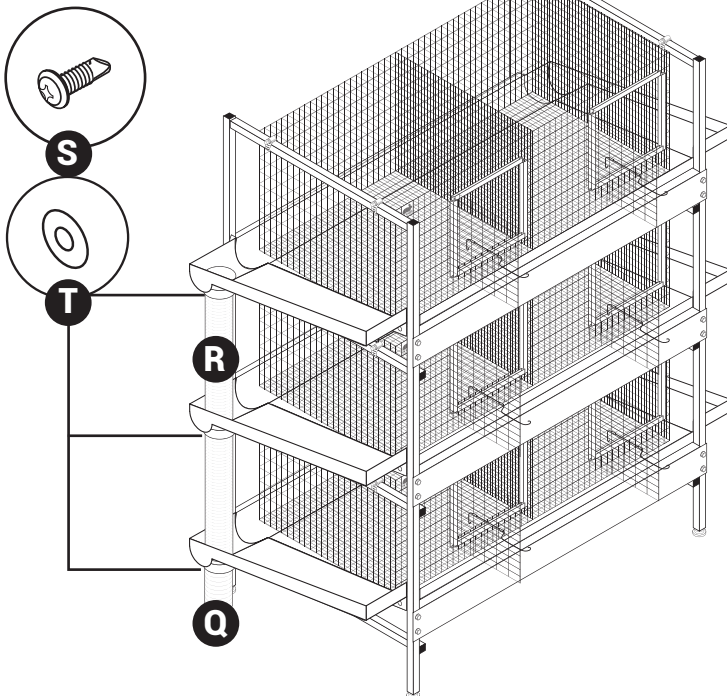

21 *Attach short drain pipe (Q) to lowest end cap w/ drain, then attach long drain pipes (R) between the upper two levels. Drain pipe should fit snug into drain holes on end caps. Using a drill driver with phillips bit, secure drain pipe to drain outlets by driving 2 Tek Screw (S) with washers (T) through center on each side of the drain outlet into the drain pipe. Connect drain to 4" or larger floor waste connection according to local codes or use an elbow to have drain outside to a collection pit.*



✓ Step-By-Step

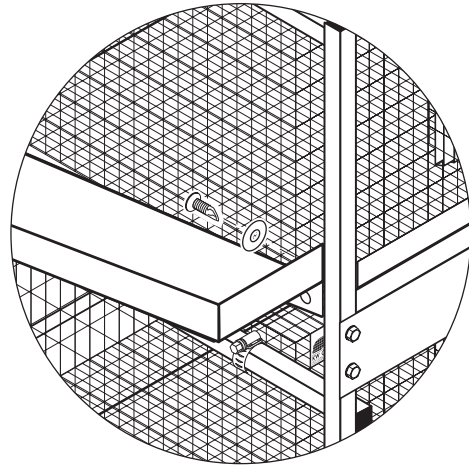
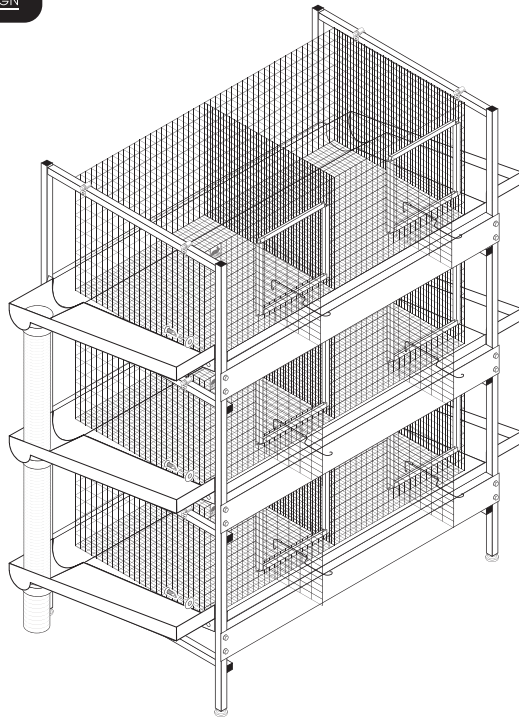

- 22** Using a drill driver with phillips bit, secure inclined wings of end drain to frame by driving a Tek Screw and washer through pre drilled holes into center of metal frame. Repeat steps until all wings are secured.

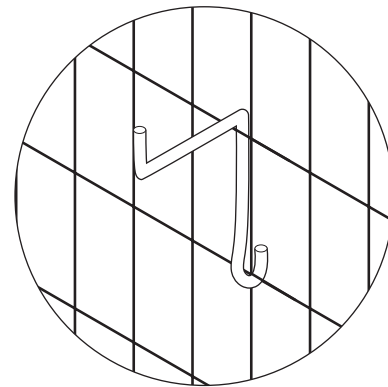
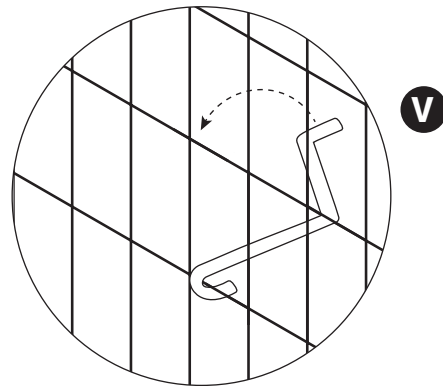
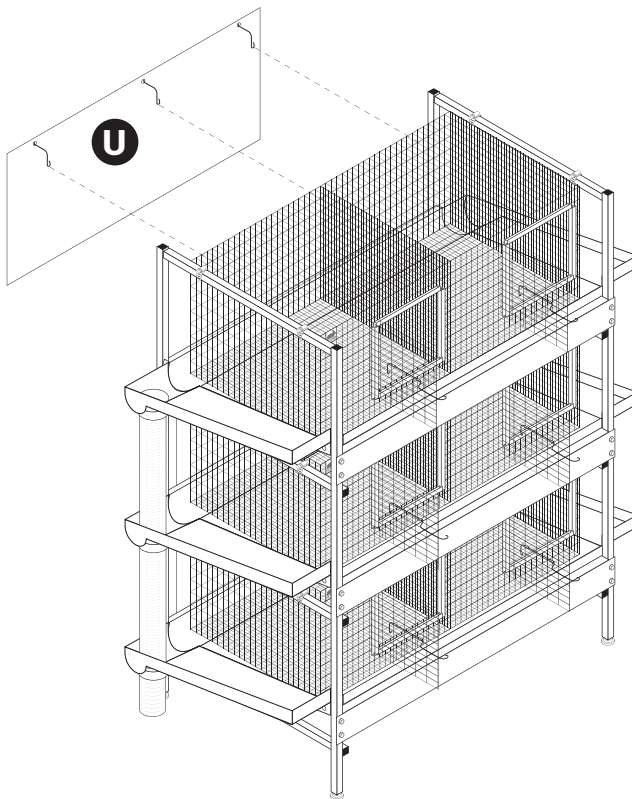

- 23** Attach back splash (U) to top level of system using the wire holders (V) provided. To secure wire holders to cage, attach the lower hook onto the cage wire, then rotate holder so that the 80° bend sits over a horizontal cage wire. Repeat steps for bottom levels of cages until all the back splashes are installed.